

Runva

Since 1989



TRUCKS WHEELS 2022

Version NO.:RCE2022





Runva is the first electric winch manufacturer in China mainland. Since the foundation in 1989, we are dedicated to innovate technology and improve performance continuously. Runva has grown to develop and manufacture a broad range of winches: electric, hydraulic and gasoline winch, from 2000 to 25000lbs, which can be found in diverse industries of over 50 countries. Our vision is to be a leading solution provider to deliver customer individualized product and superior service.

All Efforts For Reliable



Company milestone

Honored National IP Advantage Enterprise

2019



2017

Certified National High and New Technology Enterprise

Awarded TSC Product Development Supplier

2015



2010

Participated drafting 3 Specifications for military vehicle winch

Received PLA Second Technology Prize

2009



2004

Became Wal-mart winch supplier

Developed the first electric winch in China

1997

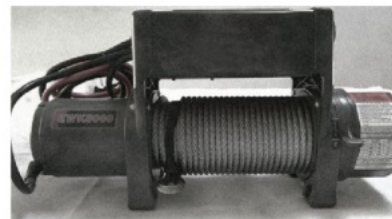

Over *20* Years' Experience In Winch Industry

More Professional

More Reliable



Table of contents

6-14 **ATV&UTV WINCH**



15-26 **4X4 ELECTRIC WINCH**



27-28 **ELECTRIC HOIST**



29-42 **HYDRAULIC WINCH**



43-47 **ACCESSORIES AND OTHER PRODUCT**



ATV&UTV WINCH

Runva ATV&UTV winches offer high performance at an affordable price in capacities ranging from 2000-5500lbs. When you want your ATV or UTV to go further, Runva ATV&UTV winch is your best choice.



U type



D type



A type

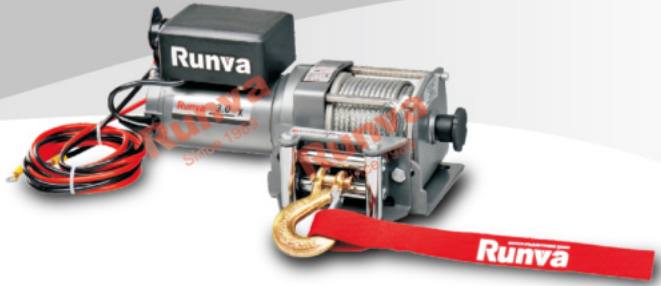

EWK 2000

SPECIFICATIONS

Rated line pull: 2000 lbs (907 kgs)

Motor: permanent magnet

12V: Input: 1.7kW/2.3hp; Output: 0.6kW/0.8hp

24V: Input: 1.9kW/2.6hp; Output: 0.7kW/0.9hp

Brake: Self-lock

Geartrain: Full steel

Gear reduction ratio: 153:1

Clutch: Full spooling

Cable (Dia x L): Ø5/32" x 49' (Ø4mm x 15m)

Drum size (Dia x L): Ø1.24" x 2.87" (Ø31.5mm x 73mm)

Mounting bolt pattern: 3.13" (79.5mm); 2-M8

Net weight: 15.0lbs/6.8kgs

DIMENSIONS

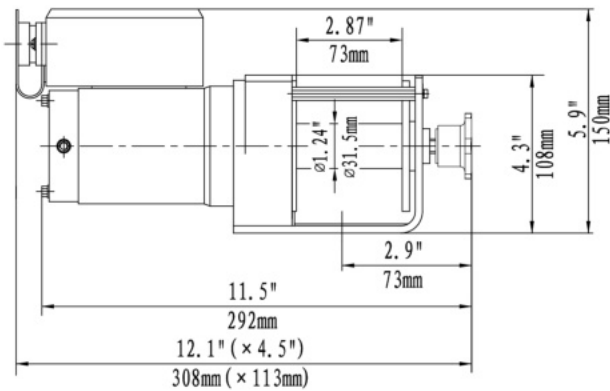

12V DC PERFORMANCE SPECS (first layer)

Line Pull	Line Speed	Motor	Pull by layer:
Lbs.(kgs)	Ft/min. (M/min.)	Current	layer/Lbs.(kgs)
0	10.5(3.2)	15amps	2/1630(739)
500 (227)	9.2(2.8)	25amps	3/1380(626)
1000 (454)	7.5(2.3)	40amps	4/1190(540)
1500 (680)	5.9(1.8)	70amps	5/1050(476)
2000 (907)	3.3(1.0)	90amps	6/940(426)

EWX 3000

SPECIFICATIONS

Rated line pull: 3000 lbs (1361 kgs)

Motor: permanent magnet

12V: Input: 2.2kW/2.9hp; Output: 0.8kW/1.1hp

24V: Input: 2.4kW/3.2hp; Output: 0.9kW/1.2hp

Brake: Self-lock

Geartrain: Full steel

Gear reduction ratio: 153:1

Clutch: Full spooling

Cable (Dia x L): Ø3/16" x 46' (Ø4.8mm x 14m)

Drum size (Dia x L): Ø1.24" x 2.87" (Ø31.5mm x 73mm)

Mounting bolt pattern: 3.13" (79.5mm); 2-M8

Net weight: 21.6lbs/9.8kgs

DIMENSIONS

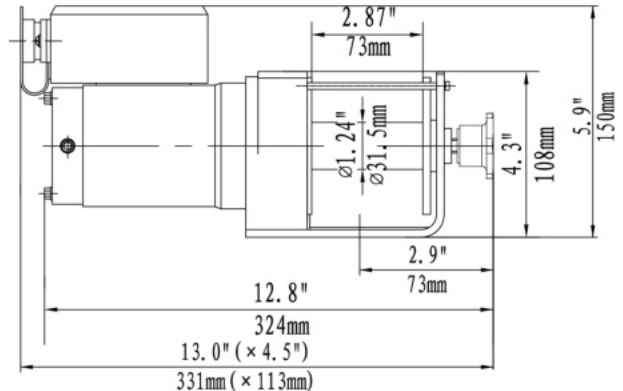

12V DC PERFORMANCE SPECS (first layer)

Line Pull	Line Speed	Motor	Pull by layer:
Lbs.(kgs)	Ft/min. (M/min.)	Current	layer/Lbs.(kgs)
0	10.2(3.1)	18amps	2/2370(1075)
500 (227)	8.2(2.5)	60amps	3/1960(889)
1000 (454)	7.5(2.3)	90amps	4/1670(756)
2000 (907)	5.9(1.8)	130amps	5/1460(662)
3000 (1361)	4.3(1.3)	180amps	6/1290(585)



EWP 3500

SPECIFICATIONS

Rated line pull: 3500 lbs (1588 kgs)

Motor: permanent magnet

12V:Input:2.4kW/3.2hp;Output:1.0kW/1.3hp

24V:Input:2.9kW/3.9hp;Output:1.2kW/1.6hp

Brake: Self-lock

Geartrain: Full steel

Gear reduction ratio: 170:1

Clutch: Cam

Cable(Dia×L): Ø7/32"×42.0'(Ø5.4mm×12.8m)

Drum size(Dia×L): Ø1.46"×3.15"(Ø37mm×80mm)

Mounting bolt pattern: 4.9"×3"(124mm×76mm);4-M8

Net weight: 22.0lbs/10.0kgs

DIMENSIONS

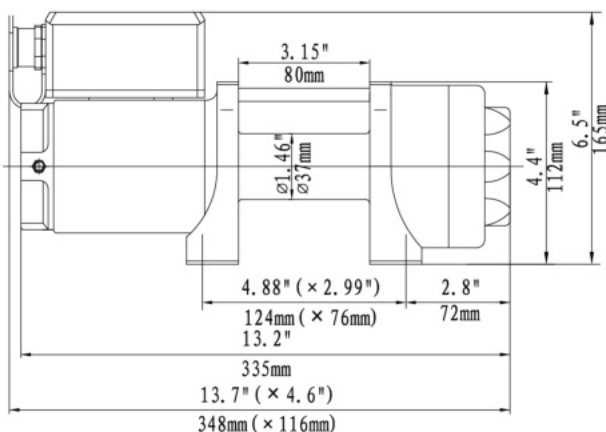

12V DC PERFORMANCE SPECS (first layer)

Line Pull Lbs.(kgs)	Line Speed Ft/min. (M/min.)	Motor Current	Pull by layer: layer/Lbs.(kgs)
0	10.2(3.1)	20amps	2/2789(1265)
1000 (454)	8.9(2.7)	75amps	3/2319(1052)
2000 (907)	7.5(2.3)	130amps	4/1984(900)
3500 (1588)	4.6(1.4)	200amps	5/1733(786)

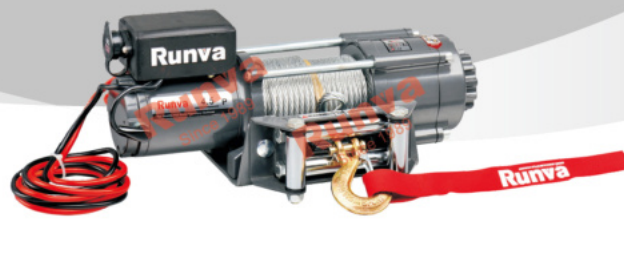

EWP 4500

SPECIFICATIONS

Rated line pull: 4500 lbs (2041 kgs)

Motor: permanent magnet

12V:Input:2.5kW/3.4hp;Output:1.1kW/1.4hp

24V:Input:2.6kW/3.5hp;Output:1.2kW/1.5hp

Brake: Mechanical spring

Geartrain: Full steel

Gear reduction ratio: 166:1

Clutch: Cam

Cable(Dia×L): Ø15/64"×47.6'(Ø6mm×14.5m)

Drum size(Dia×L): Ø2.0"×4.9"(Ø50.4mm×125mm)

Mounting bolt pattern: 6.6"×3"(168mm×76.2mm);4-M8

Net weight: 34.2lbs/15.5kgs

DIMENSIONS

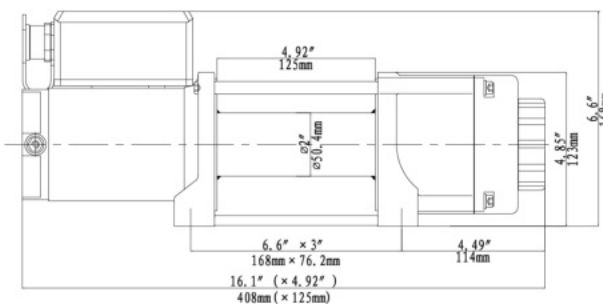

12V DC PERFORMANCE SPECS (first layer)

Line Pull Lbs.(kgs)	Line Speed Ft/min. (M/min.)	Motor Current	Pull by layer: layer/Lbs.(kgs)
0	12.8(3.9)	28amps	1/4500 (2041)
1000 (454)	9.8(3.0)	80amps	2/3841(1742)
2000 (907)	8.5(2.6)	120amps	3/3310(1501)
3000 (1361)	6.9(2.1)	160amps	4/2907(1319)
4500 (2041)	4.6(1.4)	220amps	

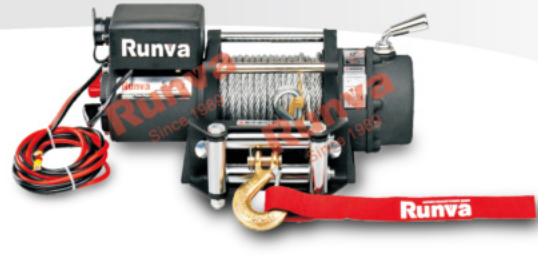

EWX 4500

SPECIFICATIONS

Rated line pull: 4500 lbs (2041 kgs)

Motor: permanent magnet

12V: Input: 2.4kW/3.2hp; Output: 1.0kW/1.3hp

24V: Input: 2.9kW/3.9hp; Output: 1.3kW/1.7hp

Brake: Automatic screw cone

Geartrain: 3-stage planetary steel gear

Gear reduction ratio: 172:1

Clutch: Sliding geared ring clutch

Cable (Dia x L): Ø15/64" x 47.6' (Ø6.0mm x 14.5m)

Drum size (Dia x L): Ø1.77" x 3.7" (Ø45mm x 93mm)

Mounting bolt pattern: 5.1" x 3.78" (129mm x 96mm) 4-M8

Net weight: 28.7lbs/13.0kgs

DIMENSIONS

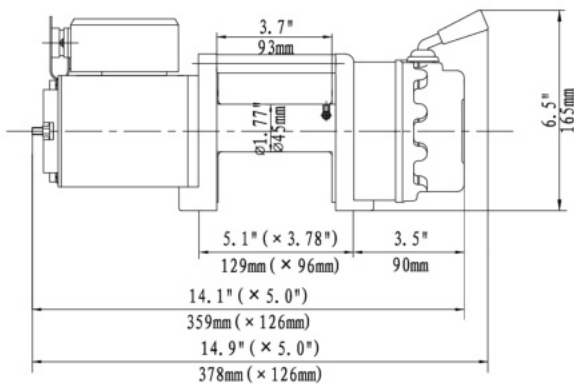

12V DC PERFORMANCE SPECS (first layer)

Line Pull Lbs.(kgs)	Line Speed Ft/min. (M/min.)	Motor Current	Pull by layer: layer/Lbs.(kgs)
0	11.6(3.6)	20amps	1/4500(2041)
1500 (680)	9.2(2.8)	70amps	2/3642(1652)
2500 (1134)	7.8(2.4)	100amps	3/3060(1388)
3500 (1588)	6.6(2.0)	140amps	4/2639(1197)
4500 (2041)	4.9(1.5)	200amps	5/2253(1022)

EWX 5500

SPECIFICATIONS

Rated line pull: 5500 lbs (2495 kgs)

Motor: permanent magnet

12V: Input: 2.4kW/3.2hp; Output: 1.0kW/1.3hp

24V: Input: 2.9kW/3.9hp; Output: 1.3kW/1.7hp

Brake: Automatic screw cone

Geartrain: 3-stage planetary steel gear

Gear reduction ratio: 172:1

Clutch: Sliding geared ring clutch

Cable (Dia x L): Ø9/32" x 45.9' (Ø7.2mm x 14.0m)

Drum size (Dia x L): Ø1.77" x 5.0" (Ø45mm x 127mm)

Mounting bolt pattern: 6.3" x 3.78" (159mm x 96mm) 4-M8

Net weight: 30.6lbs/13.9kgs

DIMENSIONS

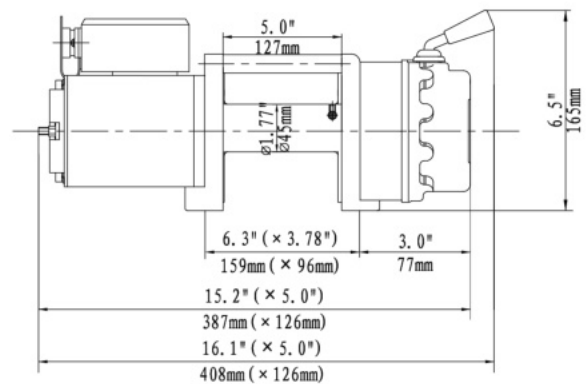

12V DC PERFORMANCE SPECS (first layer)

Line Pull Lbs.(kgs)	Line Speed Ft/min. (M/min.)	Motor Current	Pull by layer: layer/Lbs.(kgs)
0	11.2(3.4)	25amps	1/5500 (2495)
1500 (680)	8.9(2.7)	50amps	2/4311(1955)
2500 (1134)	7.5(2.3)	80amps	3/3544(1608)
4500 (2041)	5.2(1.6)	120amps	4/3009(1365)
5500 (2495)	4.6(1.4)	190amps	

SUP SERIES

The SUP winch is high efficiency with 3-stage planetary gear train. Constructed with ultra-strength alloy diecasted gear ring and stand, the SUP series is ideal choice for those needing a high performance/price ratio winch.





SUP 2500

SPECIFICATIONS

Rated line pull:

2500 lbs (1135 kgs)

Motor: permanent magnet

12V: Input: 1.9kW/2.6hp;

Output: 0.85kW/1.1hp

Brake: Mechanical spring

Geartrain: Full steel

Gear reduction ratio: 136:1

Clutch: Cam

Cable (Dia x L): Ø3/16" x 45.9' (Ø4.8mm x 14m)

Drum size (Dia x L): Ø2.0" x 3.2" (Ø50mm x 80mm)

Mounting bolt pattern: 4.9" x 3" (124mm x 76.2mm) 4-M8

Net weight: 22lbs/ 10kgs

DIMENSIONS

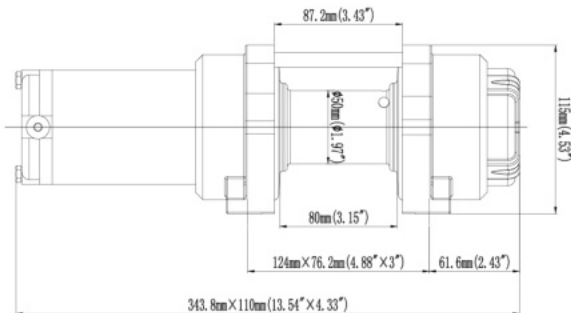

12V DC PERFORMANCE SPECS (first layer)

Line Pull Lbs.(kgs)	Line Speed Ft/min. (M/min.)	Motor Current	Pull by layer: layer/Lbs.(kgs)
0	17.7(5.4)	22amps	1/2500(1135)
1000 (454)	12.1(3.7)	80amps	2/2127(965)
2000 (907)	9.0(2.7)	110amps	3/1851(840)
2500 (1135)	6.9(2.1)	130amps	4/1638(743)
			5/1469(666)

SUP 3500

SPECIFICATIONS

Rated line pull:

3500 lbs (1588 kgs)

Motor: permanent magnet

12V: Input: 2.4kW/3.2hp;

Output: 1kW/1.3hp

Brake: Mechanical spring

Geartrain: Full steel

Gear reduction ratio: 136:1

Clutch: Cam

Cable (Dia x L): Ø7/32" x 42' (Ø5.4mm x 12.8m)

Drum size (Dia x L): Ø2.0" x 3.2" (Ø50mm x 80mm)

Mounting bolt pattern: 4.9" x 3" (124mm x 76.2mm) 4-M8

Net weight: 22.7lbs/ 10.3kgs

DIMENSIONS

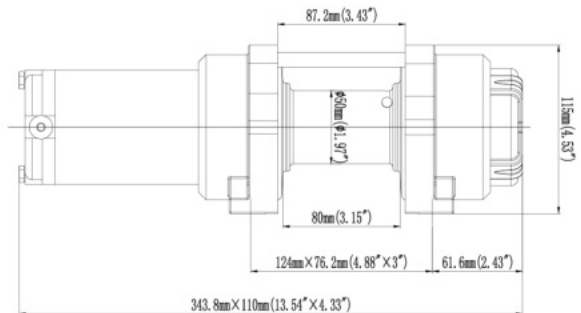

12V DC PERFORMANCE SPECS (first layer)

Line Pull Lbs.(kgs)	Line Speed Ft/min. (M/min.)	Motor Current	Pull by layer: layer/Lbs.(kgs)
0	17.7(5.4)	22amps	1/3500 (1588)
1000 (454)	12.1(3.7)	80amps	2/2929(1329)
2500 (1135)	6.9(2.1)	130amps	3/2518(1142)
3500 (1588)	5.9(1.8)	170amps	4/2208(1002)

Runva

Since 1989



RISE SERIES

The SUP winch is high efficiency with 3-stage planetary gear train. Constructed with ultra-strength alloy diecasted gear ring and stand, the SUP series is ideal choice for those needing a high performance/price ratio winch.



RISE 2500

SPECIFICATIONS

Rated line pull:

2500 lbs (1135 kgs)

Motor: permanent magnet

12V: Input: 2.4kW/3.2hp;

Output: 1.0kW/1.3hp

24V: Input: 2.4kW/3.2hp;

Output: 1.05kW/1.37hp

Brake: Mechanical spring

Geartrain: Full steel

Gear reduction ratio: 166:1

Clutch: Cam

Cable (Dia x L):

Ø3/16" x 45.9' (Ø4.8mm x 14.0m)

Drum size (Dia x L):

Ø2.0" x 3.2" (Ø50.4mm x 82mm)

Mounting bolt pattern:

4.9" x 3" (124mm x 76.2mm); 4-M8

Net weight: 26.9lbs/12.2kgs

RISE 3500

SPECIFICATIONS

Rated line pull:

3500 lbs (1588 kgs)

Motor: permanent magnet

12V: Input: 2.4kW/3.2hp;

Output: 1.0kW/1.3hp

24V: Input: 2.4kW/3.2hp;

Output: 1.05kW/1.37hp

Brake: Mechanical spring

Geartrain: Full steel

Gear reduction ratio: 166:1

Clutch: Cam

Cable (Dia x L):

Ø7/32" x 42.0' (Ø5.4mm x 12.8m)

Drum size (Dia x L):

Ø2.0" x 3.2" (Ø50.4mm x 82mm)

Mounting bolt pattern:

4.9" x 3" (124mm x 76.2mm); 4-M8

Net weight: 26.9lbs/12.2kgs

RISE 4500

SPECIFICATIONS

Rated line pull:

4500 lbs (2041 kgs)

Motor: permanent magnet

12V: Input: 2.5kW/3.4hp;

Output: 1.1kW/1.4hp

24V: Input: 2.6kW/3.5hp;

Output: 1.2kW/1.5hp

Brake: Mechanical spring

Geartrain: Full steel

Gear reduction ratio: 166:1

Clutch: Cam

Cable (Dia x L):

Ø1/4" x 47.6' (Ø6.0mm x 14.5m)

Drum size (Dia x L):

Ø2.0" x 5.0" (Ø50.4mm x 126mm)

Mounting bolt pattern:

6.6" x 3" (168mm x 76.2mm); 4-M8

Net weight: 32.4lbs/14.7kgs

DIMENSIONS

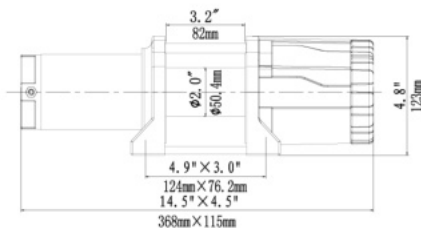

12V DC PERFORMANCE SPECS (first layer)

Line Pull	Line Speed	Motor	Pull by layer:
Lbs.(kgs)	Ft/min. (M/min.)	Current	layer/Lbs.(kgs)
0	17.0(5.2)	28amps	1/2500 (1135)
1000 (454)	9.8(3.0)	80amps	2/2129(966)
2000 (907)	8.2(2.5)	140amps	3/1854(842)
2500 (1135)	7.2(2.2)	150amps	4/1642(745)

DIMENSIONS

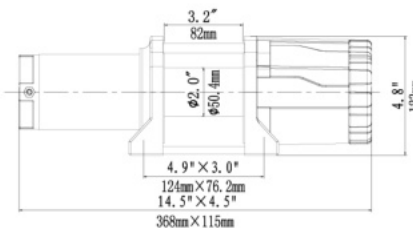

12V DC PERFORMANCE SPECS (first layer)

Line Pull	Line Speed	Motor	Pull by layer:
Lbs.(kgs)	Ft/min. (M/min.)	Current	layer/Lbs.(kgs)
0	17.0(5.2)	28amps	1/3500 (1588)
1000 (454)	9.8(3.0)	80amps	2/2932(1331)
2500 (1135)	7.2(2.2)	150amps	3/2523(1145)
3500 (1588)	5.9(1.8)	170amps	4/2214(1005)

DIMENSIONS

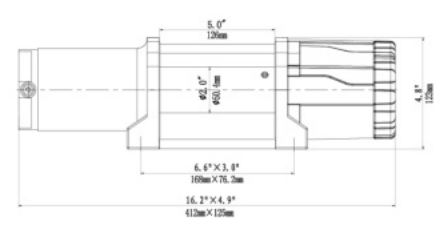

12V DC PERFORMANCE SPECS (first layer)

Line Pull	Line Speed	Motor	Pull by layer:
Lbs.(kgs)	Ft/min. (M/min.)	Current	layer/Lbs.(kgs)
0	12.5(3.8)	28amps	1/4500 (2041)
1000 (454)	8.5(2.6)	140amps	2/3833(1740)
2500 (1135)	6.2(1.9)	170amps	3/3338(1515)
4500 (2041)	5.2(1.6)	220amps	4/2957(1342)



ROMA SERIES

Innovative, smart, and compact, the ROMA winch has advanced visual impact. All-steel 3-stage planetary gear train and brake built-in motor end deliver powerful performance, reliable braking and durability.

ROMA 5000

SPECIFICATIONS

Rated line pull: 5000 lbs (2268 kgs)

Motor: permanent magnet

12V: Input: 2.4kW/3.2hp; Output: 1.0kW/1.3hp

24V: Input: 2.9kW/3.9hp; Output: 1.3kW/1.7hp

Gear reduction ratio: 206:1

Brake: Mechanical spring

Geartrain: Full steel

Cable (Dia x L): $\varnothing 1/4" \times 45.9'$ ($\varnothing 6.0\text{mm} \times 14\text{m}$)

Rope (Dia x L): $\varnothing 9/32" \times 45.9'$ ($\varnothing 7.0\text{mm} \times 14\text{m}$)

Clutch: Cam

Drum size (Dia x L): $\varnothing 1.97" \times 5.4"$ ($\varnothing 50\text{mm} \times 138\text{mm}$)

Mounting bolt pattern: $6.6" \times 3.0"$ ($168\text{mm} \times 76.2\text{mm}$) 4-M8

Net weight: 25.6lbs/ 11.6kgs

12V DC PERFORMANCE SPECS (first layer)

Line Pull	Line Speed	Motor	Pull by layer:
Lbs.(kgs)	Ft/min. (M/min.)	Current	layer/Lbs.(kgs)
0	13.5(4.1)	24amps	1/5000(2268)
1500(680)	11.2(3.4)	50amps	2/4075(1848)
3500(1588)	9.5(2.9)	130amps	3/3439(1559)
5000(2268)	2(0.6)	300amps	4/2974(1349)



DIMENSIONS

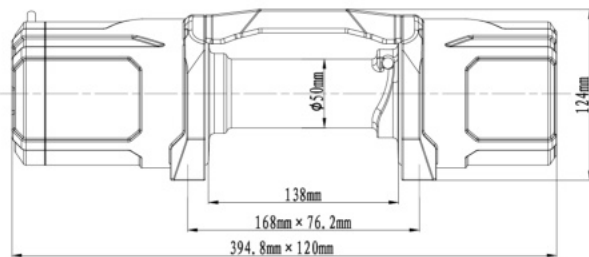

4 × 4 ELECTRIC WINCH

With pulling capacities over 5000lbs,Runva 4×4winches feature rugged struction ideal for heavy duty recovery application.With ultra-high performance,Runva4×4 winches deliver the best value for off-roaders.



U type



S type

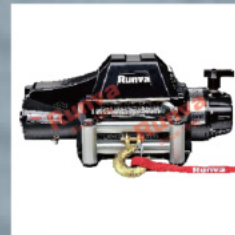

F type





EWX 9500

SPECIFICATIONS

Rated line pull:

9500 lbs (4309 kgs)

Motor:series wound

12V:Input:4.6kW/6.1hp;

Output:2.1kW/2.8hp

24V:Input:6.5kW/8.7hp;

Output:2.8kW/3.8hp

Brake: Automatic screw cone

Geartrain: 3-stage planetary steel gear

Gear reduction ratio: 230:1

Clutch: Sliding geared ring clutch

Cable(Dia×L):

Ø3/8"×85'(Ø9.2mm×26m)

Drum size(Dia×L):

Ø2.48"×8.8"(Ø63mm×223mm)

Mounting bolt pattern:

10"×4.5"(254×114.3mm)4-M10

Net weight: 80.7lbs/36.6kgs

EWX 10000

SPECIFICATIONS

Rated line pull:

10000 lbs (4536 kgs)

Motor:series wound

12V:Input:4.3kW/5.8hp;

Output:2.3kW/3.1hp

24V:Input:5.9kW/7.9hp;

Output:3.0kW/4.0hp

Brake: Automatic screw cone

Geartrain: 3-stage planetary steel gear

Gear reduction ratio: 230:1

Clutch: Sliding geared ring clutch

Cable(Dia×L):

Ø3/8"×85'(Ø9.2mm×26m)

Drum size(Dia×L):

Ø2.48"×8.8"(Ø63mm×223mm)

Mounting bolt pattern:

10"×4.5"(254×114.3mm)4-M10

Net weight: 88.2lbs/40.0kgs

EWX 12000

SPECIFICATIONS

Rated line pull:

12000 lbs (5443 kgs)

Motor:series wound

12V:Input:5.4kW/7.2hp;

Output:2.7kW/3.6hp

24V:Input:5.3kW/7.1hp;

Output:3.3kW/4.4hp

Brake: Automatic screw cone

Geartrain: 3-stage planetary steel gear

Gear reduction ratio: 230:1

Clutch: Sliding geared ring clutch

Cable(Dia×L):

Ø13/32"×83.7'(Ø10.2mm×25.5m)

Drum size(Dia×L):

Ø2.48"×8.8"(Ø63mm×223mm)

Mounting bolt pattern:

10"×4.5"(254×114.3mm)4-M10

Net weight: 92.6lbs/42.0kgs

DIMENSIONS

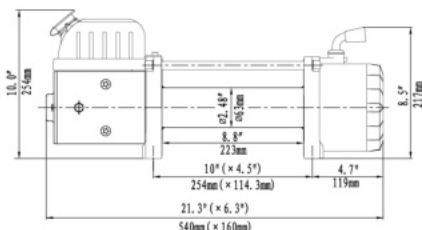

12V DC PERFORMANCE SPECS (first layer)

Line Pull Lbs.(kgs)	Line Speed Ft/min. (M/min.)	Motor Current	Pull by layer: layer/Lbs.(kgs)
0	19.7(6.0)	80amps	1/9500(4309)
3000 (1361)	12.5(3.8)	170amps	2/7706(3495)
6000 (2722)	9.8(3.0)	260amps	3/6482(2940)
9500 (4309)	6.2(1.9)	380amps	4/5593(2537)

DIMENSIONS

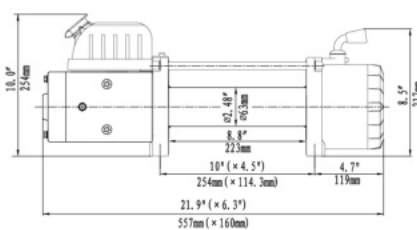

12V DC PERFORMANCE SPECS (first layer)

Line Pull Lbs.(kgs)	Line Speed Ft/min. (M/min.)	Motor Current	Pull by layer: layer/Lbs.(kgs)
0	20.7(6.3)	80amps	1/10000(4536)
4000 (1814)	12.5(3.8)	230amps	2/7969(3615)
7000 (3175)	9.5(2.9)	290amps	3/6624(3005)
10000 (4536)	6.2(1.9)	360amps	4/5667(2571)

DIMENSIONS

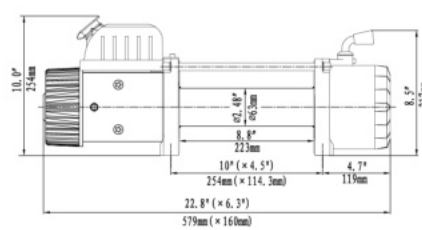

12V DC PERFORMANCE SPECS (first layer)

Line Pull Lbs.(kgs)	Line Speed Ft/min. (M/min.)	Motor Current	Pull by layer: layer/Lbs.(kgs)
0	22.3(6.8)	100amps	1/12000(5443)
4000 (1814)	13.1(4.0)	220amps	2/9563(4338)
8000 (3629)	9.8(3.0)	330amps	3/7948(3605)
12000 (5443)	5.9(1.8)	450amps	4/6800(3084)



EWN 10000

SPECIFICATIONS

Rated line pull:

10000 lbs (4536 kgs)

Motor:series wound

12V:Input:4.6kW/6.1hp;

Output:2.1kW/2.8hp

24V:Input:6.5kW/8.7hp;

Output:2.8kW/3.8hp

Brake: Automatic screw cone

Geartrain: 3-stage planetary steel gear

Gear reduction ratio: 332:1

Clutch: Full spooling

Cable(Dia×L):

Ø3/8"×85.3'(Ø9.2mm×26m)

Drum size(Dia×L):

Ø2.8"×8.6"(Ø72mm×219mm)

Mounting bolt pattern:

10"×4.5"(254×114.3mm)4-M12

Net weight: 128.5lbs/58.3kgs



EWN 12000

SPECIFICATIONS

Rated line pull:

12000 lbs (5443 kgs)

Motor:series wound

12V:Input:5.4kW/7.2hp;

Output:2.7kW/3.6hp

24V:Input:5.3kW/7.1hp;

Output:3.3kW/4.4hp

Brake: Automatic screw cone

Geartrain: 3-stage planetary steel gear

Gear reduction ratio: 332:1

Clutch: Full spooling

Cable(Dia×L):

Ø13/32"×83.7'(Ø10.2mm×25.5m)

Drum size(Dia×L):

Ø2.8"×8.6"(Ø72mm×219mm)

Mounting bolt pattern:

10"×4.5"(254×114.3mm)4-M12

Net weight: 132.3lbs/61kgs



EWN 15000

SPECIFICATIONS

Rated line pull:

15000 lbs (6804 kgs)

Motor:series wound

12V:Input:4.2kW/5.5hp;

Output:2.5kW/3.4hp

24V:Input:5.5kW/7.5hp;

Output:3.2kW/4.4hp

Brake: Automatic screw cone

Geartrain: 3-stage planetary steel gear

Gear reduction ratio: 446:1

Clutch: Full spooling

Cable(Dia×L):

Ø7/16"×83.7'(Ø11mm×25.5m)

Drum size(Dia×L):

Ø3.5"×8.8"(Ø88mm×217mm)

Mounting bolt pattern:

10"×4.5"(254×114.3mm)4-M12

Net weight: 162.9lbs/73.8kgs

DIMENSIONS

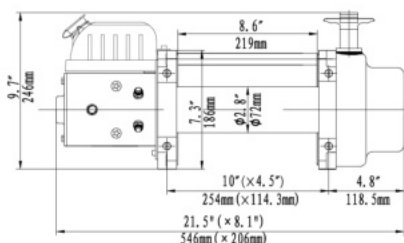

12V DC PERFORMANCE SPECS (first layer)

Line Pull Lbs.(kgs)	Line Speed Ft/min. (M/min.)	Motor Current	Pull by layer: layer/Lbs.(kgs)
0	13.8(4.2)	65amps	1/10000(4536)
3000 (1361)	9.2(2.8)	123amps	2/8000(3629)
6000 (2722)	6.6(2.0)	220amps	3/6700(3039)
8000 (3629)	5.6(1.7)	255amps	4/5747(2607)
10000 (4536)	5.2(1.6)	300amps	

DIMENSIONS

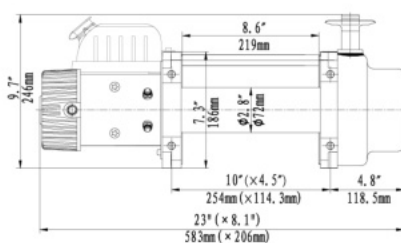

12V DC PERFORMANCE SPECS (first layer)

Line Pull Lbs.(kgs)	Line Speed Ft/min. (M/min.)	Motor Current	Pull by layer: layer/Lbs.(kgs)
0	15.7(4.8)	50amps	1/12000 (5443)
6000 (2722)	10.2(3.1)	130amps	2/9800(4445)
8000 (3629)	8.5(2.6)	210amps	3/8300(3765)
10000 (4536)	6.6(2.0)	250amps	4/7200(3266)
12000 (5443)	5.29(1.8)	310amps	

DIMENSIONS

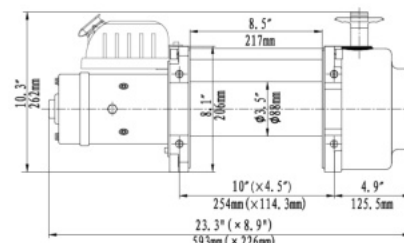

12V DC PERFORMANCE SPECS (first layer)

Line Pull Lbs.(kgs)	Line Speed Ft/min. (M/min.)	Motor Current	Pull by layer: layer/Lbs.(kgs)
0	15.0(4.6)	60amps	1/15000 (6804)
8000 (3629)	8.2(2.5)	220amps	2/12000 (5443)
10000 (4536)	6.0(1.9)	260amps	3/10100(4581)
12000 (5443)	5.6(1.7)	300amps	4/8720(3955)
15000 (6804)	4.3(1.3)	330amps	

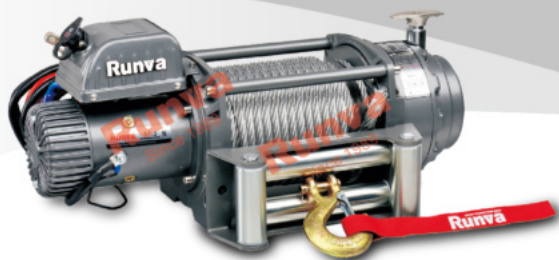

EWN 17500

SPECIFICATIONS

Rated line pull: 17500 lbs (7938 kgs)

Motor:series wound

12V:Input:5.4kW/7.1hp;Output:2.9kW/3.9hp

24V:Input:6.0kW/7.9hp;Output:3.1kW/4.1hp

Brake: Automatic screw cone

Geartrain: 3-stage planetary steel gear

Gear reduction ratio:430:1

Clutch: Full spooling

Cable(Dia×L): Ø15/32"×87'(Ø12mm×26.5m)

Drum size(Dia×L): Ø3.5"×8.5"(Ø89mm×217mm)

Mounting bolt pattern:

10"×4.5"(254mm×114.3mm)

10"×6.5"(254mm×165.1mm) 8-M12

Net weight: 147.7lbs/67.0kgs



EWN 20000

SPECIFICATIONS

Rated line pull: 20000 lbs (9072 kgs)

Motor:series wound

12V:Input:5.4kW/7.1hp;Output:2.9kW/3.9hp

24V:Input:6.0kW/7.9hp;Output:3.21kW/4.1hp

Brake: Automatic screw cone

Geartrain: 3-stage planetary steel gear

Gear reduction ratio: 430:1

Clutch: Full spooling

Cable(Dia×L): Ø15/32"×87'(Ø12mm×26.5m)

Drum size(Dia×L): Ø3.5"×8.5"(Ø89mm×217mm)

Mounting bolt pattern:

10"×4.5"(254mm×114.3mm)

10"×6.5"(254mm×165.1mm) 8-M12

Net weight: 158.7lbs/72.0kgs

DIMENSIONS

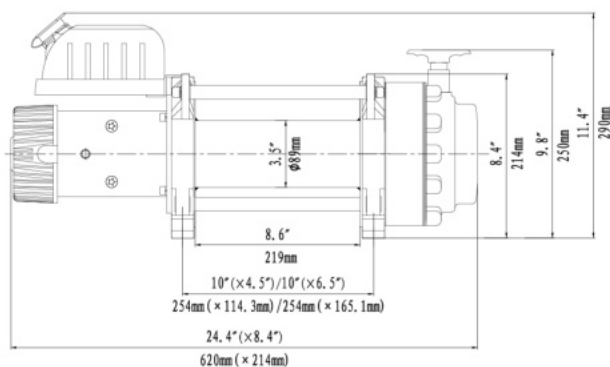

12V DC PERFORMANCE SPECS (first layer)

Line Pull Lbs.(kgs)	Line Speed Ft/min. (M/min.)	Motor Current	Pull by layer: layer/Lbs.(kgs)
0	19.7(6.0)	100amps	1/17500 (7938)
10000 (4536)	5.6(1.7)	320amps	2/14140(6414)
14000 (6350)	4.6(1.4)	380amps	3/11862(5381)
17500 (7938)	3.0(0.9)	450amps	4/10217(4634)

DIMENSIONS

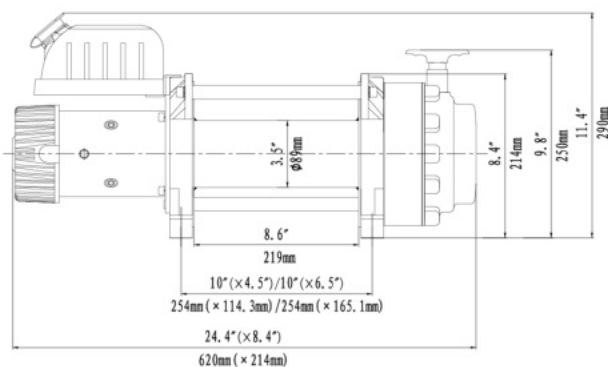

12V DC PERFORMANCE SPECS (first layer)

Line Pull Lbs.(kgs)	Line Speed Ft/min. (M/min.)	Motor Current	Pull by layer: layer/Lbs.(kgs)
0	19.7(6.0)	100amps	1/20000 (9072)
6000 (2722)	7.2(2.2)	220amps	2/16160(7330)
10000 (4536)	5.6(1.7)	320amps	3/13557(6149)
14000 (6350)	4.6(1.4)	380amps	4/11677(5297)
20000 (9072)	3.0(0.9)	480amps	



EWD 10000

SPECIFICATIONS

Rated line pull: 10000 lbs (4536 kgs)

Motor: series wound

12V:Input:4.3kW/5.7hp;Output:2.1kW/2.8hp

24V:Input:4.1kW/5.5hp;Output:2.8kW/3.8hp

Brake: Automatic screw cone

Geartrain: 3-stage planetary steel gear

Gear reduction ratio: 223:1(Low speed);71.6:1(High speed)

Clutch: Two-speed shift

Cable(Dia×L): Ø3/8"×85'(Ø9.2mm×26m)

Drum size(Dia×L): Ø2.48"×8.8"(Ø63mm×223mm)

Mounting bolt pattern: 10"×4.5"(254mm×114.3mm)4-M10

Net weight: 86.0lbs/39kgs



EWD 12000

SPECIFICATIONS

Rated line pull: 12000 lbs (5443 kgs)

Motor: series wound

12V:Input:5.4kW/7.2hp;Output:2.4kW/3.2hp

24V:Input:4.8kW/6.4hp;Output:3.1kW/4.2hp

Brake: Automatic screw cone

Geartrain: 3-stage planetary steel gear

Gear reduction ratio: 223:1(Low speed);71.6:1(High speed)

Clutch: Two-speed shift

Cable(Dia×L): Ø13/32"×83.7'(Ø10.2mm×25.5m)

Drum size(Dia×L): Ø2.48"×8.8"(Ø63mm×223mm)

Mounting bolt pattern: 10"×4.5"(254mm×114.3mm)4-M10

Net weight: 90.4lbs/41kgs

DIMENSIONS

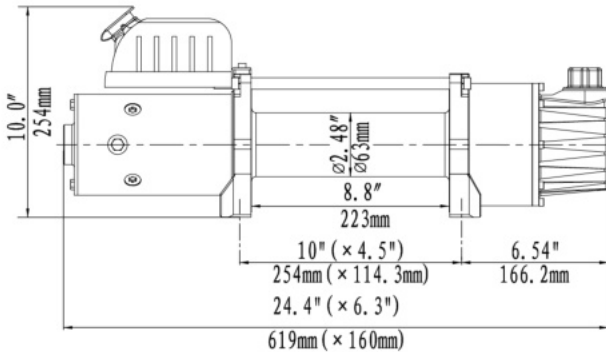

12V DC PERFORMANCE SPECS (first layer)

Line Pull	Line Speed	Motor	Pull by layer:
Lbs.(kgs)	Ft/min. (M/min.)	Current	layer/Lbs.(kgs)
0	28.9(8.8)	70amps	1/10000(4536)
4000 (1814)	9.8(3.0)	190amps	2/7969(3615)
6000 (2722)	8.6(2.7)	230amps	3/6624(3005)
8000 (3629)	7.9(2.0)	280amps	4/5667(2571)
10000 (4536)	4.9(1.5)	360amps	

DIMENSIONS

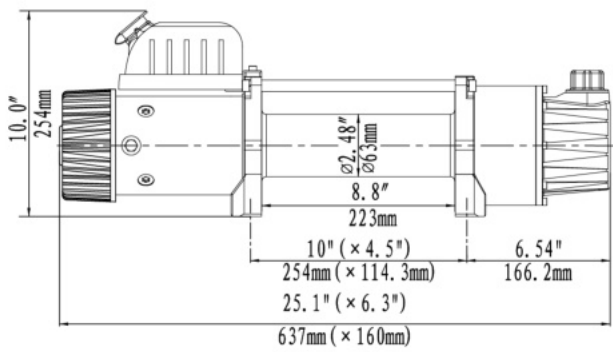

12V DC PERFORMANCE SPECS (first layer)

Line Pull	Line Speed	Motor	Pull by layer:
Lbs.(kgs)	Ft/min. (M/min.)	Current	layer/Lbs.(kgs)
0	29.5(9.0)	70amps	1/12000 (5443)
3000 (1361)	11.5(3.5)	170amps	2/9562(4337)
6000 (2722)	7.9(2.4)	250amps	3/7948(3605)
9000 (4082)	6.6(2.0)	345amps	4/6800(3084)
12000 (5443)	4.9(1.5)	450amps	



Designed specifically for hard-core competition, EWS winch provides ultra power with dual IP67 sealed motors. High durable planetary reducer ensures perfect performance in heavy duty.

EWS 10000

SPECIFICATIONS

Rated line pull: 10000 lbs (4536 kgs)

Motor: series wound

12V: Input: 5.4kW/7.2hp; Output: 2.7kW/3.6hp

24V: Input: 5.3kW/7.1hp; Output: 3.3kW/4.4hp

Brake: Patented ratchet-paw

Geartrain: 3-stage planetary alloy gear

Gear reduction ratio: 80:1

Waterproof: IP67

Cable (Dia x L): $\varnothing 3/8" \times 85'$ ($\varnothing 9.2\text{mm} \times 26\text{m}$)

Drum size (Dia x L): $\varnothing 2.8" \times 8.4"$ ($\varnothing 72\text{mm} \times 214\text{mm}$)

Mounting bolt pattern: $10" \times 4.5"$ ($254\text{mm} \times 114.3\text{mm}$) 4-M10

Net weight: 136.5 lbs / 61.9 kgs



DIMENSIONS

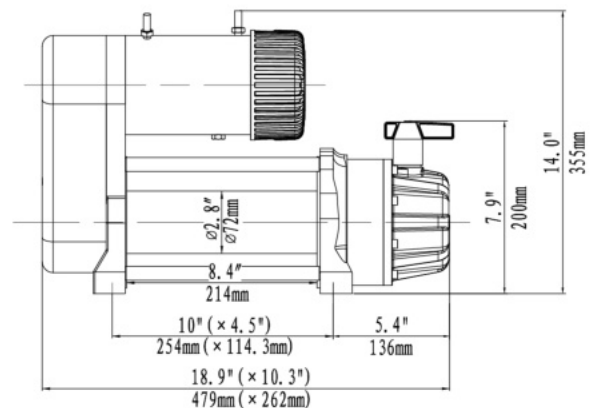

12V DC PERFORMANCE SPECS (first layer)

	Line Speed	Motor	Pull by layer:
Lbs.(kgs)	Ft/min. (M/min.)	Current	layer/Lbs.(kgs)
	50.2(15.3)	150amps	1/10000(4536)
4000(1816)	22.6(6.8)	420amps	2/8153(3698)
6000(2722)	18.7(5.7)	580amps	3/6881(3121)
8000(3629)	15.7(4.8)	700amps	4/2974(1349)
10000(4536)	12.8(3.9)	860amps	4/5953(2700)



Optional



Control box



Dual Motor Drive

EWB SERIES

EWB series are reliable performance electric winches with innovative brake. High-efficient transmission delivers high pull-in speed and low noise. All-stainless out-installed components ensure these winches work more durable.



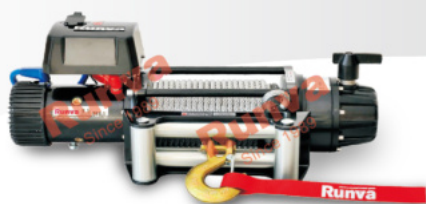

EWB 9500-Q

SPECIFICATIONS

Rated line pull:

9500 lbs (4309 kgs)

Motor:series wound

12V:Input:5.4kW/7.2hp;

Output:2.7kW/3.6hp

24V:Input:5.3kW/7.1hp;

Output:3.3kW/4.4hp

Brake: kachet paw

Geartrain: 3-stage planetary steel gear

Gear reduction ratio: 108:1

Clutch: Rotary

Waterproof: IP67

Cable(Dia×L):

Ø3/8"×85.3'(Ø9.2mm×26m)

Drum size(Dia×L):

Ø2.48"×8.54"(Ø63mm×217mm)

Mounting bolt pattern:

10"×4.5"(254×114.3mm)4-M10

Net weight: 83.8lbs/38kgs



EWB 9500

SPECIFICATIONS

Rated line pull:

9500 lbs (4309 kgs)

Motor:series wound

12V:Input:4.6kW/6.1hp;

Output:2.1kW/2.8hp

24V:Input:6.5kW/8.7hp;

Output:2.8kW/3.8hp

Brake: kachet paw

Geartrain: 3-stage planetary steel gear

Gear reduction ratio: 228:1

Clutch: Rotary

Waterproof: IP67

Cable(Dia×L):

Ø3/8"×85'(Ø9.2mm×26m)

Drum size(Dia×L):

Ø2.48"×8.5"(Ø63mm×217mm)

Mounting bolt pattern:

10"×4.5"(254×114.3mm)4-M10

Net weight: 87.1lbs/39.5kgs

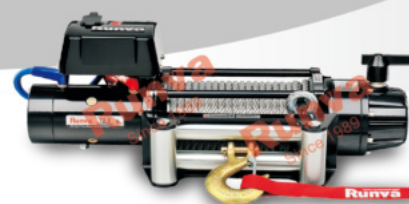

EWB 12500

SPECIFICATIONS

Rated line pull:

12500 lbs (5670 kgs)

Motor:series wound

12V:Input:5.9kW/7.9hp;

Output:2.4kW/3.2hp

24V:Input:4.8kW/6.4hp;

Output:3.1kW/4.2hp

Brake: kachet paw

Geartrain: 3-stage planetary steel gear

Gear reduction ratio: 228:1

Clutch: Rotary

Waterproof: IP67

Cable(Dia×L):

Ø13/32"×83.7'(Ø10.2mm×25.5m)

Drum size(Dia×L):

Ø2.48"×8.5"(Ø63mm×217mm)

Mounting bolt pattern:

10"×4.5"(254×114.3mm)4-M10

Net weight: 97.2lbs/44.1kgs

DIMENSIONS

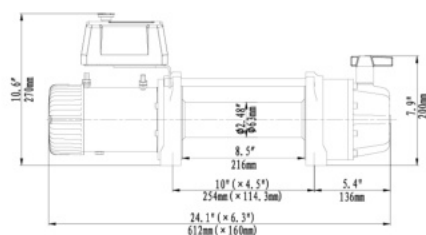

12V DC PERFORMANCE SPECS (first layer)

Line Pull Lbs.(kgs)	Line Speed Ft./min. (M/min.)	Motor Current	Pull by layer: layer/Lbs.(kgs)
0	42.7(17.0)	51amps	1/9500(4309)
3000 (1361)	18.7(5.7)	220amps	2/7706(3495)
6000 (2722)	12.1(3.7)	365amps	3/6482(2940)
9500 (4309)	7.2(2.2)	530amps	4/5593(2537)

DIMENSIONS

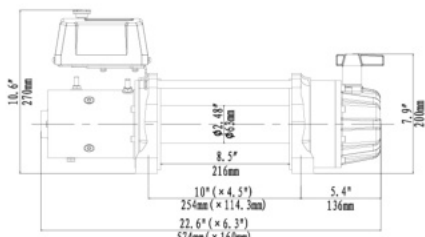

12V DC PERFORMANCE SPECS (first layer)

Line Pull Lbs.(kgs)	Line Speed Ft./min. (M/min.)	Motor Current	Pull by layer: layer/Lbs.(kgs)
0	32.2(9.8)	75amps	1/9500(4309)
3000 (1361)	14.8(4.5)	170amps	2/7706(3495)
6000 (2722)	10.5(3.2)	260amps	3/6482(2940)
9500 (4309)	6.6(2.0)	380amps	4/5593(2537)

DIMENSIONS

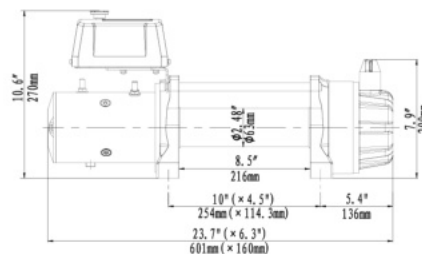

12V DC PERFORMANCE SPECS (first layer)

Line Pull Lbs.(kgs)	Line Speed Ft./min. (M/min.)	Motor Current	Pull by layer: layer/Lbs.(kgs)
0	32.8(10.0)	75amps	1/12500(5670)
3000 (1361)	15.7(4.8)	190amps	2/9776(4434)
6000 (2722)	11.5(3.5)	285amps	3/8026(3641)
9000 (4082)	8.2(2.5)	360amps	4/6808(3088)
12500 (5670)	5.2(1.6)	490amps	



EWB 18000

SPECIFICATIONS

Rated line pull:

18000 lbs (8165 kgs)

Motor:series wound

12V:Input:5.5kW/7.4hp;

Output:2.9kW/3.9hp

24V:Input:6.1kW/8.2hp;

Output:3.1kW/4.2hp

Brake: Patented ratchet-paw

Geartrain: 3-stage planetary steel gear

Gear reduction ratio: 370:1

Waterproof: IP67

Cable(Dia×L):

Ø15/32"×87' (Ø12mm×26.5m)

Drum size(Dia×L):

Ø3.46"×8.43" (Ø88mm×214mm)

Mounting bolt pattern:

10"×4.5"(254×114.3mm)

10"×6.5"(254×165.1mm)

Net weight: 147.7lbs/67kgs

DIMENSIONS

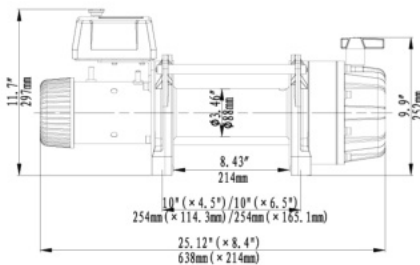

12V DC PERFORMANCE SPECS (first layer)

Line Pull	Line Speed	Motor	Pull by layer:
Lbs.(kgs)	Ft/min.	Current	layer/Lbs.(kgs)
0	26.2(8.0)	60amps	1/18000 (8165)
6000 (2722)	10.5(3.2)	180amps	2/14516(6584)
10000 (4536)	7.87(2.4)	260amps	3/12162(5516)
14000 (6350)	6.56(2.0)	320amps	4/10465(4747)
18000(8165)	4.92(1.5)	360amps	

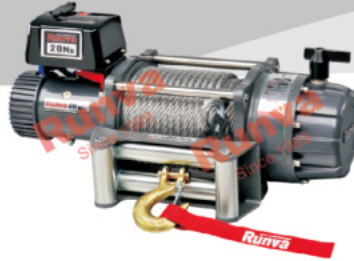

EWB 20000

SPECIFICATIONS

Rated line pull:

20000 lbs (9072 kgs)

Motor:series wound

12V:Input:5.5kW/7.4hp;

Output:2.9kW/3.9hp

24V:Input:6.1kW/8.2hp;

Output:3.1kW/4.2hp

Brake: Patented ratchet-paw

Geartrain: 3-stage planetary steel gear

Gear reduction ratio: 370:1

Waterproof: IP67

Cable(Dia×L):

Ø15/32"×87'(Ø12mm×26.5m)

Drum size(Dia×L):

Ø3.46"×8.43" (Ø88mm×214mm)

Mounting bolt pattern:

10"×4.5"(254×114.3mm)

10"×6.5"(254×165.1mm)

Net weight: 154.3lbs/70kgs

DIMENSIONS

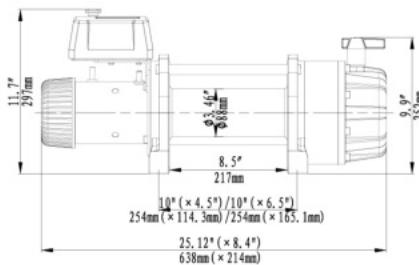

12V DC PERFORMANCE SPECS (first layer)

Line Pull	Line Speed	Motor	Pull by layer:
Lbs.(kgs)	Ft/min.	Current	layer/Lbs.(kgs)
0	26.2(8.0)	60amps	1/20000(9072)
6000 (2722)	10.5(3.2)	200amps	2/16129(7316)
10000 (4536)	7.87(2.4)	280amps	3/13513(6129)
14000 (6350)	6.56(2.0)	340amps	4/11628(5274)
17000 (7711)	5.25(1.6)	390amps	
20000 (9072)	3.9(1.2)	430amps	



EWB 25000

SPECIFICATIONS

Rated line pull:

25000lbs (11340 kgs)

Motor:series wound

24V:Input:6.1kW/8.2hp;

Output:3.1kW/4.2hp

Brake:

Patented ratchet-paw

Geartrain:

3-stage planetary steel gear

Gear reduction ratio: 450:1

Waterproof: IP67

Cable(Dia×L):

Ø7/13"×87'(Ø13.8mm×26.5m)

Drum size(Dia×L):

Ø4.72"×7.8"(Ø120mm×198mm)

Mounting bolt pattern:

10"×4.5"(254×114.3mm)

10"×7.5"(254×190.5mm)

Net weight: 219.4lbs/99.5kgs

DIMENSIONS

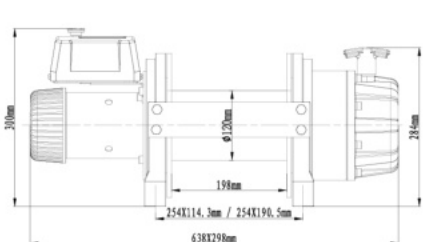

24V DC PERFORMANCE SPECS (first layer)

Line Pull	Line Speed	Motor	Pull by layer:
Lbs.(kgs)	Ft/min.	Current	layer/Lbs.(kgs)
0	30.5(9.3)	23amps	1/25000(11340)
5000(2268)	11.1(3.4)	90amps	2/20724(9400)
10000(4536)	8.2(2.5)	140amps	3/17698(8027)
15000(6804)	6.6(2.0)	180amps	4/15443(7005)
20000(9072)	5.2(1.6)	230amps	
25000(11340)	3.9(1.2)	280amps	

Runva

Since 1989



EWV /EWA SERIES

New appearance and high no load speed make EWV/EWA series winches ideal for recovery and heavy duty applications. Patented ratchet-paw brake inside gearbox prevents the drum heating. Hall protection avoids over-load damage.



EWV 9500

SPECIFICATIONS

Rated line pull:

9500 lbs (4309 kgs)

Motor:series wound

12V:Input:4.6kW/6.1hp;
Output:2.1kW/2.8hp
24V:Input:6.5kW/8.7hp;
Output:2.8kW/3.8hp

Brake:Patented ratchet-paw

Geartrain:3-stage planetary steel gear

Gear reduction ratio: 196:1

Clutch: Sliding geared ring clutch

Cable(Dia×L):

Ø3/8"×85.3'(Ø9.2mm×26m)

Drum size(Dia×L):

Ø2.48"×8.8"(Ø63mm×223mm)

Mounting bolt pattern:

10"×4.5"(254mm×114.3mm)4-M10

Net weight: 83.8lbs/38kgs

DIMENSIONS

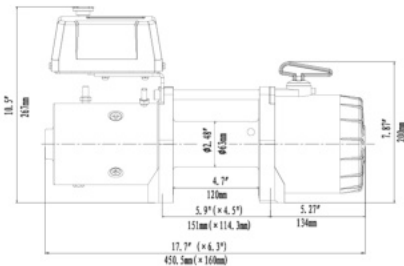

12V DC PERFORMANCE SPECS (first layer)

Line Pull Lbs.(kgs)	Line Speed Ft./min. (M/min.)	Motor Current	Pull by layer: layer/Lbs.(kgs)
0	36(11.0)	65amps	1/9500 (4309)
3000 (1361)	13.1(4.7)	150amps	2/7706(3495)
6000 (2722)	10.5(3.2)	260amps	3/6482(2940)
9500 (4309)	6.5(2.0)	355amps	4/5593(2537)



EWV 9500SG2

SPECIFICATIONS

Rated line pull:

9500 lbs (4309 kgs)

Motor:series wound

12V:Input:4.6kW/6.1hp;
Output:2.1kW/2.8hp
24V:Input:6.5kW/8.7hp;
Output:2.8kW/3.8hp

Brake: Patented ratchet-paw

Geartrain:3-stage planetary steel gear

Gear reduction ratio: 196:1

Clutch: Sliding geared ring clutch

Cable(Dia×L):

Ø3/8"×45.9'(Ø9.2mm×14m)

Drum size(Dia×L):

Ø2.48"×4.7"(Ø63mm×120mm)

Mounting bolt pattern:

5.9"×4.5"(151mm×114.3mm)4-M10

Net weight: 72.8lbs/33kgs

DIMENSIONS

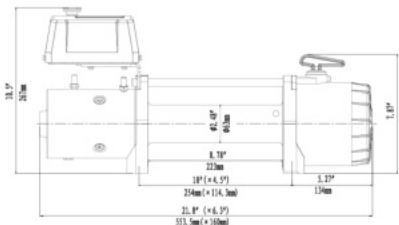

12V DC PERFORMANCE SPECS (first layer)

Line Pull Lbs.(kgs)	Line Speed Ft./min. (M/min.)	Motor Current	Pull by layer: layer/Lbs.(kgs)
0	36(11.0)	65amps	1/9500 (4309)
3000 (1361)	13.1(4.7)	150amps	2/7706(3495)
6000 (2722)	10.5(3.2)	260amps	3/6482(2940)
9500 (4309)	6.5(2.0)	355amps	4/5593(2537)



EWV 12000

SPECIFICATIONS

Rated line pull:

12000 lbs (5443 kgs)

Motor:series wound

12V:Input:4.6kW/6.1hp;
Output:2.1kW/2.8hp
24V:Input:6.5kW/8.7hp;
Output:2.8kW/3.8hp

Brake: Patented ratchet-paw

Geartrain:3-stage planetary steel gear

Gear reduction ratio: 253:1

Clutch: Sliding geared ring clutch

Cable(Dia×L):

Ø13/32"×83.7'(Ø10.2mm×25.5m)

Drum size(Dia×L):

Ø2.48"×8.8"(Ø63mm×223mm)

Mounting bolt pattern:

10"×4.5"(254mm×114.3mm)4-M10

Net weight: 89.7lbs/40.7kgs

DIMENSIONS

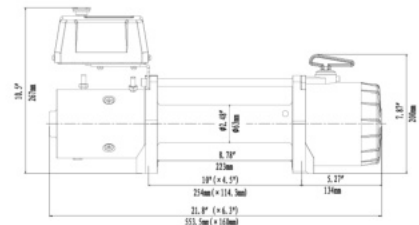

12V DC PERFORMANCE SPECS (first layer)

Line Pull Lbs.(kgs)	Line Speed Ft./min. (M/min.)	Motor Current	Pull by layer: layer/Lbs.(kgs)
0	29.5(9.0)	60amps	1/12000 (5443)
4000 (1814)	12.5(3.8)	160amps	2/9563(4338)
8000 (3629)	8.2(2.5)	260amps	3/7948(3605)
12000 (5443)	4.9(1.5)	380amps	4/6800(3084)



EWA 9500

SPECIFICATIONS

Rated line pull: 9500 lbs (4309 kgs)

Motor:series wound

12V:Input:4.6kW/6.1hp;Output:2.1kW/2.8hp

24V:Input:6.5kW/8.7hp;Output:2.8kW/3.8hp

Brake: Patented ratchet-paw

Geartrain: 3-stage planetary steel gear

Gear reduction ratio: 196:1

Clutch: Sliding geared ring clutch

Cable(Dia×L): Ø3/8"×85.3'(Ø9.2mm×26m)

Drum size(Dia×L): Ø2.48"×8.8"(Ø63mm×223mm)

Mounting bolt pattern:

10"×4.5"(254mm×114.3mm)4-M10

Net weight: 88.8lbs/40.3kgs



EWA 12000

SPECIFICATIONS

Rated line pull: 12000 lbs (5443 kgs)

Motor:series wound

12V:Input:4.6kW/6.1hp;Output:2.1kW/2.8hp

24V:Input:6.5kW/8.7hp;Output:2.8kW/3.8hp

Brake: Patented ratchet-paw

Geartrain: 3-stage planetary steel gear

Gear reduction ratio: 253:1

Clutch: Sliding geared ring clutch

Cable(Dia×L): Ø13/32"×83.7'(Ø10.2mm×25.5m)

Drum size(Dia×L): Ø2.48"×8.8"(Ø63mm×223mm)

Mounting bolt pattern:

10"×4.5"(254mm×114.3mm)4-M10

Net weight: 94.4lbs/42.8kgs

DIMENSIONS

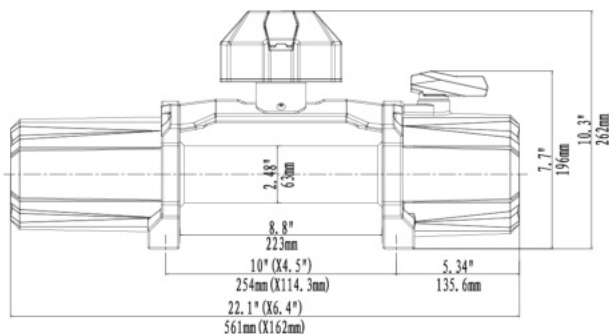

12V DC PERFORMANCE SPECS (first layer)

Line Pull	Line Speed	Motor	Pull by layer:
Lbs.(kgs)	Ft/min. (M/min.)	Current	layer/Lbs.(kgs)
0	36(11.0)	65amps	1/9500 (4309)
3000 (1361)	13.1(4.7)	150amps	2/7706(3495)
6000 (2722)	10.5(3.2)	260amps	3/6482(2940)
9500 (4309)	6.5(2.0)	355amps	4/5593(2537)

DIMENSIONS

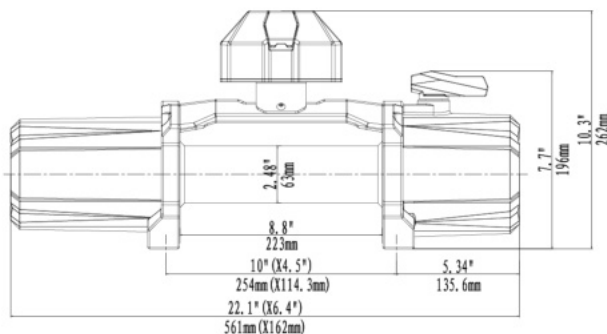

12V DC PERFORMANCE SPECS (first layer)

Line Pull	Line Speed	Motor	Pull by layer:
Lbs.(kgs)	Ft/min. (M/min.)	Current	layer/Lbs.(kgs)
0	29.5(9.0)	60amps	1/12000 (5443)
4000 (1814)	12.5(3.8)	160amps	2/9563(4338)
8000 (3629)	8.2(2.5)	260amps	3/7948(3605)
12000 (5443)	4.9(1.5)	380amps	4/6800(3084)

ELECTRIC HOIST



As the pioneer of DC hoist, EH Series ensure operator safety while lifting and moving loads. The unique design makes them continuously work under various complex condition for over 10 minutes, and IP68 waterproof design prevents rain and dust.



EH 1100i

SPECIFICATIONS

Rated line pull:

1100 lbs (499 kgs)

Motor: permanent magnet

12V: Input: 1.7kW/2.3hp;

Output: 0.9kW/1.2hp

24V: Input: 2.6kW/3.5hp;

Output: 1.2kW/1.6hp

Brake: Automatic screw cone

Gear reduction ratio: 172:1

Cable (Dia x L):

Ø3/16" x 45.9' (Ø4.8mm x 14m)

No retated wire 19*7 optional

Drum size (Dia x L):

Ø2.48" x 4.8" (Ø63mm x 122mm)

Mounting bolt pattern:

6.26" x 3.8" (159mm x 96mm) 4-M8

Net weight: 32.8lbs/14.9kgs

DIMENSIONS

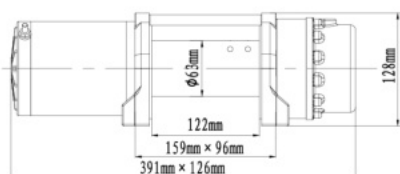

12V DC PERFORMANCE SPECS (first layer)

Line Pull Lbs.(kgs)	Line Speed Ft./min. (M./min.)	Motor Current	Pull by layer: layer/Lbs.(kgs)
0	13.8(4.2)	19amps	1/1100 (499)
400 (181)	13.1(4.0)	30amps	2/963(437)
800 (363)	12.5(3.8)	39amps	3/857(389)
1100 (499)	11.5(3.5)	54amps	



EH 2000

SPECIFICATIONS

Rated line pull:

2000 lbs (907 kgs)

Motor: series wound

12V: Input: 4.6kW/6.1hp;

Output: 2.1kW/2.8hp

24V: Input: 6.5kW/8.7hp;

Output: 2.8kW/3.8hp

Brake: Automatic screw cone/ratchet-paw

Gear reduction ratio: 228:1

Cable (Dia x L):

Ø15/64" x 47.6' (Ø6.0mm x 14.5m)

No retated wire 19*7 optional

Drum size (Dia x L):

Ø3.5" x 4.25" (Ø89mm x 108mm)

Mounting bolt pattern:

5.95" x 4.5" (151mm x 114.3mm) 4-M10

Net weight: 66.8lbs/30.3kgs

DIMENSIONS

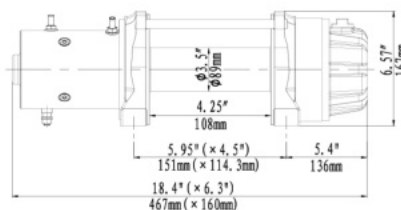

12V DC PERFORMANCE SPECS (first layer)

Line Pull Lbs.(kgs)	Line Speed Ft./min. (M./min.)	Motor Current	Pull by layer: layer/Lbs.(kgs)
0	42.0(12.8)	75amps	1/2000 (907)
500 (227)	29.2(8.9)	85amps	2/1776(805)
1000 (454)	25.6(7.8)	100amps	3/1597(724)
1500 (680)	22.0(6.7)	120amps	
2000 (907)	17.1(5.2)	150amps	



EH 2600

SPECIFICATIONS

Rated line pull:

2600 lbs (1180 kgs)

Motor: series wound

12V: Input: 5.5kW/7.4hp;

Output: 2.9kW/3.9hp

24V: Input: 6.1kW/8.2hp;

Output: 3.1kW/4.2hp

Brake: Automatic screw cone/ratchet-paw

Gear reduction ratio: 370:1

Cable (Dia x L):

Ø13/41" x 59' (Ø8.1mm x 18m)

No retated wire 19*7 optional

Drum size (Dia x L):

Ø4.7" x 5.1" (Ø120mm x 130mm)

Mounting bolt pattern:

6.75" x 4.5" (171.4mm x 114.3mm)

6.75" x 6.5" (171.4mm x 165.1mm)

Net weight: 122.4lbs/55.5kgs

DIMENSIONS

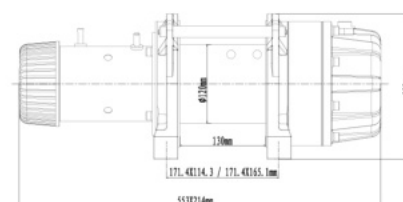

12V DC PERFORMANCE SPECS (first layer)

Line Pull Lbs.(kgs)	Line Speed Ft./min. (M./min.)	Motor Current	Pull by layer: layer/Lbs.(kgs)
0	24.6(7.5)	60amps	1/2600 (1180)
1000 (453)	19.4(5.9)	80amps	2/2253(1022)
2000 (907)	14.8(4.5)	110amps	3/1988(901)
2600 (1180)	12.5(3.8)	125amps	

HYDRAULIC WINCH

Runva hydraulic winches provide you with a continuous duty solution to your winch requirements. Designed with the toughest commercial application in mind, all winches feature total reliability to handle sustained pulls.

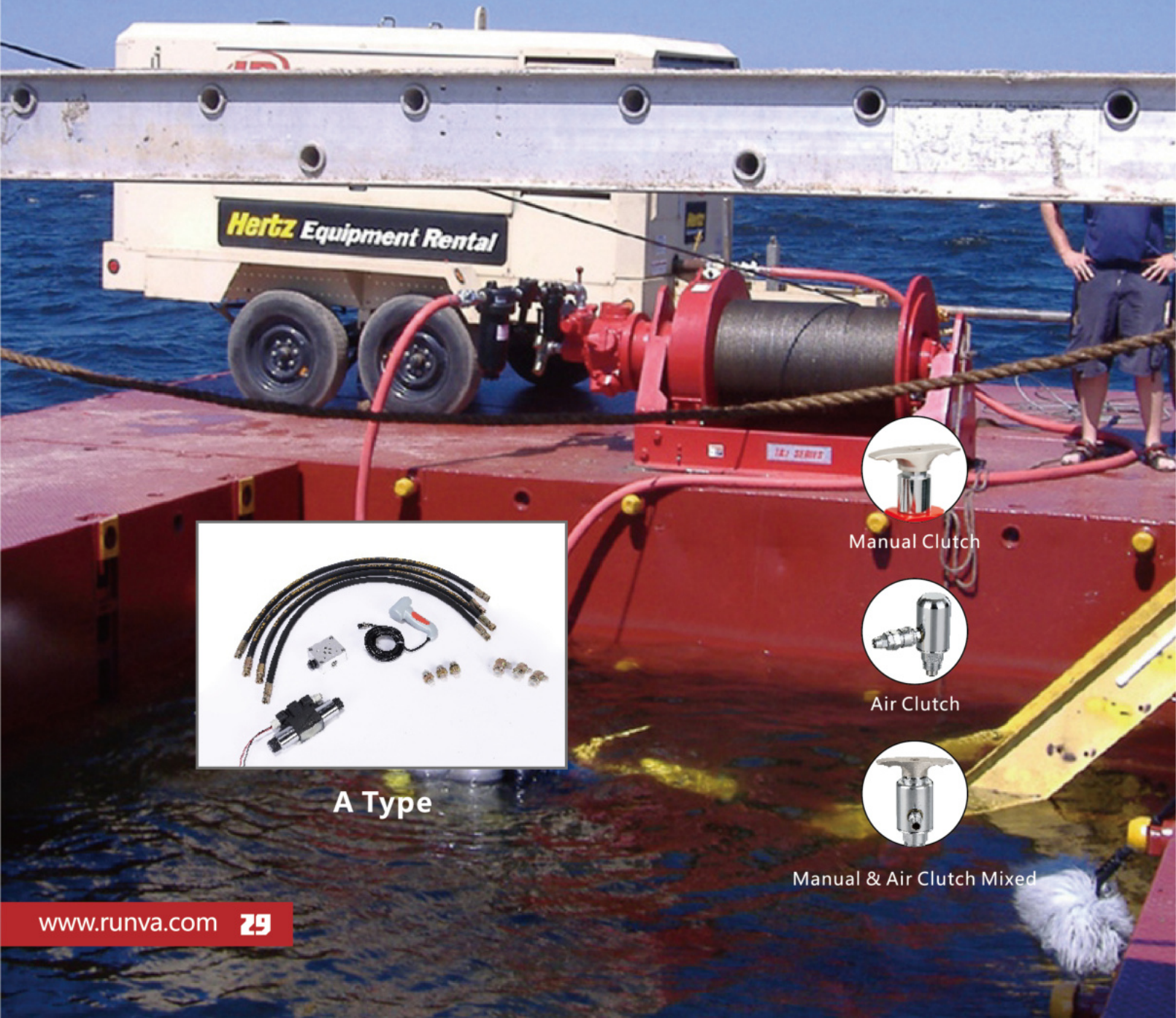

A Type



Manual Clutch



Air Clutch



Manual & Air Clutch Mixed



HWX 10000

SPECIFICATIONS

Rated line pull: 10000 lbs (4536 kgs)

Motor displacement: 65ml/r

Oil flow: 5 ~ 45L/min

Pressure: 10Mpa

Gear reduction ratio: 28:1

Cable(Dia×L): Ø3/8"×85.3'(Ø9.2mm×26m)

Drum size(Dia×L): Ø2.48"×8.45"(Ø63mm×217mm)

Mounting bolt pattern: 10"×4.5"(254mm×114.3mm)4-M12

Net weight: 91.0lbs/41.3kgs



HWX 12000

SPECIFICATIONS

Rated line pull: 12000 lbs (5443 kgs)

Motor displacement: 65ml/r

Oil flow: 5~45L/min

Pressure: 11Mpa

Gear reduction ratio: 28:1

Cable(Dia×L): Ø13/32"×83.7'(Ø10.2mm×25.5m)

Drum size(Dia×L): Ø2.48"×8.45"(Ø63mm×217mm)

Mounting bolt pattern: 10"×4.5"(254mm×114.3mm)4-M12

Net weight: 94lbs/42.8kgs

DIMENSIONS

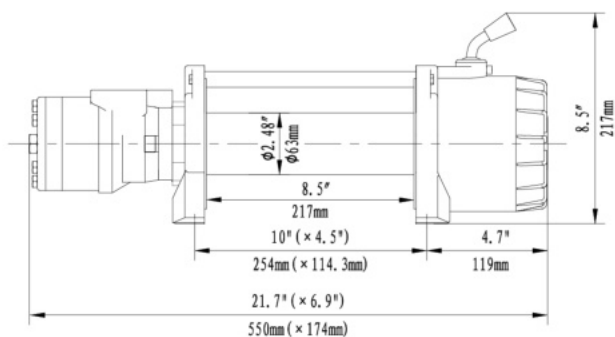

DIMENSIONS

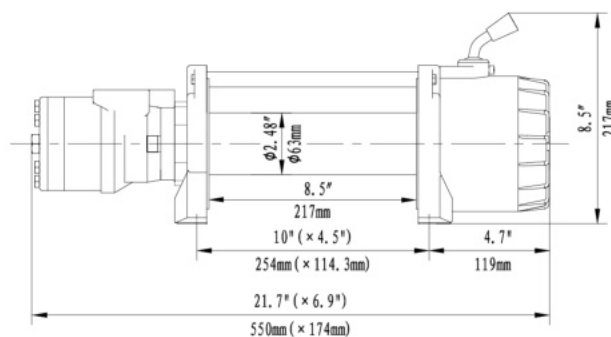

PERFORMANCE SPECS (first layer)

Line Pull	Pressure	Line Speed	Flow	Pull by layer:
Lbs.(kgs)	Mpa(Psi)	Ft/min. (M/min.)	G/min. (L/min.)	layer/Lbs.(kgs)
0	2.0(290.1)	2.0(0.6)	1.3(5)	1/10000 (4536)
4000 (1814)	3.8(551.1)	3.6(1.1)	2.6(10)	2/7969(3615)
6000 (2722)	7.2(1044.2)	7.5(2.3)	5.3(20)	3/6624(3005)
8000 (3629)	8.6(1247.3)	13.1(4.0)	9.2(35)	4/5667(2571)
10000 (4536)	10.0(1450.3)	17.4(5.3)	11.9(45)	

PERFORMANCE SPECS (first layer)

Line Pull	Pressure	Line Speed	Flow	Pull by layer:
Lbs.(kgs)	Mpa(Psi)	Ft/min. (M/min.)	G/min. (L/min.)	layer/Lbs.(kgs)
0	2.0(290.1)	1.6(0.5)	1.3(5)	1/12000 (5443)
3000 (1361)	3.3(478.6)	3.6(1.1)	2.6(10)	2/9563(4338)
6000 (2722)	7.2(1044.2)	7.5(2.3)	5.2(20)	3/7949(3606)
9000 (4082)	9.2(1344.3)	13.1(4.0)	9.2(35)	4/6801(3085)
12000 (5443)	11.0(1595.4)	17.4(5.3)	11.9(45)	



HWN 10000

SPECIFICATIONS

Rated line pull:	10000 lbs (4536 kgs)
Motor displacement:	65ml/r
Oil flow:	5~45L/min
Pressure:	11.5Mpa
Brake:	Automatic braking
Geartrain:	2-stage planetary gear
Gear reduction ratio:	25.5:1
Clutch:	Air,manual,air&manual optional
Cable(Dia×L):	Ø13/32"×83.7'(Ø10.2mm×25.5m)
Drum size(Dia×L):	Ø2.8"×8.5"(Ø72mm×216mm)
Mounting bolt pattern:	10"×4.5"(254mm×114.3mm)4-M12
Net weight:	134.5lbs/61.0kgs

HWN 12000

SPECIFICATIONS

Rated line pull:	12000 lbs (5443 kgs)
Motor displacement:	65ml/r
Oil flow:	5~45L/min
Pressure:	14Mpa
Brake:	Automatic braking
Geartrain:	2-stage planetary gear
Gear reduction ratio:	25.5:1
Clutch:	Air,manual,air&manual optional
Cable(Dia×L):	Ø7/16"×83.7'(Ø11mm×25.5m)
Drum size(Dia×L):	Ø2.8"×8.5"(Ø72mm×216mm)
Mounting bolt pattern:	10"×4.5"(254mm×114.3mm)4-M12
Net weight:	139.0lbs/63.0kgs

HWN 15000

SPECIFICATIONS

Rated line pull:	15000 lbs (6804 kgs)
Motor displacement:	80ml/r
Oil flow:	5~60L/min
Pressure:	13Mpa
Brake:	Automatic braking
Geartrain:	2-stage planetary gear
Gear reduction ratio:	33.4:1
Clutch:	Air,manual,air&manual optional
Cable(Dia×L):	Ø15/32"×87'(Ø12mm×26.5m)
Drum size(Dia×L):	Ø3.5"×8.4"(Ø89mm×214mm)
Mounting bolt pattern:	10"×4.5"(254mm×114.3mm)4-M12
Net weight:	151.5lbs/68.5kgs

DIMENSIONS

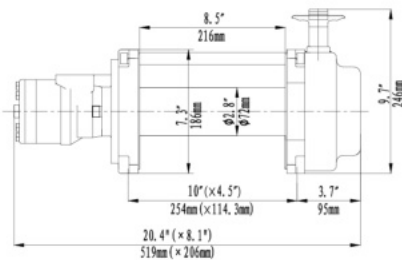

PERFORMANCE SPECS (first layer)

Line Pull Lbs.(kgs)	Pressure Mpa(Psi)	Flow G/min (L/min)	Line Speed Ft/min. (M/min.)
0	2.0(290.1)	1.3(5.0)	2.3(0.7)
3000 (1361)	3.4(453.1)	2.6(10)	4.6(1.4)
6000 (2722)	6.8(986.2)	5.3(20.0)	8.9(2.7)
9000 (4082)	10.3(1493.9)	9.2(35.0)	15.1(4.6)
10000 (4536)	11.5(1668.0)	10.6(40.0)	17.4(5.3)

DIMENSIONS

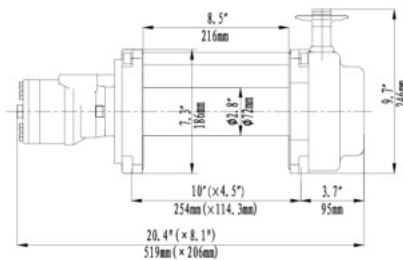

PERFORMANCE SPECS (first layer)

Line Pull Lbs.(kgs)	Pressure Mpa(Psi)	Flow G/min (L/min)	Line Speed Ft/min. (M/min.)
0	2.0(290.1)	1.3(5.0)	2.3(0.7)
3000 (1361)	3.4(453.1)	2.6(10)	4.6(1.4)
6000 (2722)	6.8(986.2)	5.3(20.0)	8.9(2.7)
10000 (4536)	11.5(1668.0)	9.2(35.0)	15.1(4.6)
12000 (5443)	14.0(2030.6)	10.6(40.0)	17.4(5.3)

DIMENSIONS

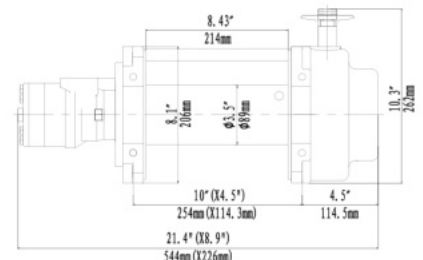

PERFORMANCE SPECS (first layer)

Line Pull Lbs.(kgs)	Pressure Mpa(Psi)	Flow G/min (L/min)	Line Speed Ft/min. (M/min.)
0	2.0(290.1)	1.3(5.0)	1.6(0.5)
5000 (2268)	4.3(623.7)	2.6(10)	3.3(1.0)
10000 (4536)	8.7(1261.8)	5.3(20.0)	6.6(2.0)
12000 (5443)	10.0(1450.3)	7.9(30.0)	9.8(3.0)
15000 (6804)	13.0(1885.4)	15.9(60.0)	19.7(6.0)



HWN 10000

SPECIFICATIONS

Rated line pull:

10000 lbs (4536 kgs)

Motor displacement: 65ml/r

Oil flow: 5~45L/min

Pressure: 12.5Mpa

Brake: Wet-type hydraulic brake

Geartrain: 2-stage planetary steel gear

Gear reduction ratio: 25.5:1

Clutch: Air,manual,air&manual optional

Waterproof: IP54

Cable(Dia×L):

Ø13/32"×83.7'(Ø10.2mm×25.5m)

Drum size(Dia×L):

Ø2.8"×8.6"(Ø72mm×219mm)

Mounting bolt pattern:

10"×4.5"(254mm×114.3mm)4-M12

Net weight: 117lbs/53kgs

DIMENSIONS

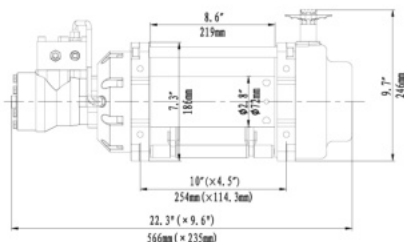

PERFORMANCE SPECS (first layer)

Line Pull Lbs.(kgs)	Pressure Mpa(Psi)	Flow G/min (L/min)	Line Speed Ft/min. (M/min.)
0	2.0(290.1)	1.3(5.0)	2.3(0.7)
3000(1361)	4.5(652.7)	2.6(10)	4.6(1.4)
6000(2722)	6.8(986.2)	5.3(20.0)	8.9(2.7)
9000(4082)	9.0(1305.3)	9.2(35.0)	15.1(4.6)
10000(4536)	12.5(1812.9)	10.6(40.0)	17.4(5.3)

HWN 12000

SPECIFICATIONS

Rated line pull:

12000 lbs (5443 kgs)

Motor displacement: 65ml/r

Oil flow: 5~45L/min

Pressure: 13.5Mpa

Brake: Wet-type hydraulic brake

Geartrain: 2-stage planetary steel gear

Gear reduction ratio: 25.5:1

Clutch: Air,manual,air&manual optional

Waterproof: IP54

Cable(Dia×L):

Ø7/16"×83.7'(Ø11mm×25.5m)

Drum size(Dia×L):

Ø2.8"×8.6"(Ø72mm×219mm)

Mounting bolt pattern:

10"×4.5" (254mm×114.3mm) 4-M12

Net weight: 117lbs/ 53 kgs

DIMENSIONS

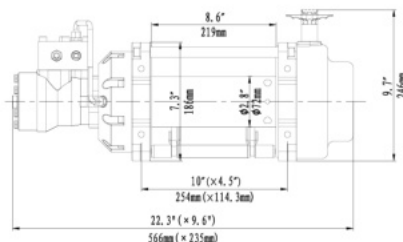

PERFORMANCE SPECS (first layer)

Line Pull Lbs.(kgs)	Pressure Mpa(Psi)	Flow G/min (L/min)	Line Speed Ft/min. (M/min.)
0	2.0(290.1)	1.3(5.0)	2.3(0.7)
3000(1361)	4.5(652.7)	2.6(10.0)	4.6(1.4)
6000(2722)	6.8(986.2)	5.3(20.0)	4.6(1.4)
9000(4082)	9.0(1305.3)	9.2(35.0)	15.1(4.6)
12000(5443)	13.5(1958)	10.6(40.0)	17.4(5.3)

HWN 15000

SPECIFICATIONS

Rated line pull:

15000 lbs (6804 kgs)

Motor displacement: 80ml/r

Oil flow: 5~60L/min

Pressure: 13Mpa

Brake: Wet-type hydraulic brake

Geartrain: 2-stage planetary steel gear

Gear reduction ratio: 33.4:1

Clutch: Air,manual,air&manual optional

Waterproof: IP54

Cable(Dia×L):

Ø15/32"×87'(Ø12mm×26.5m)

Drum size(Dia×L):

Ø3.5"×8.5"(Ø89mm×217mm)

Mounting bolt pattern:

10"×4.5"(254mm×114.3mm)4-M12

Net weight: 132lbs/60kgs

DIMENSIONS

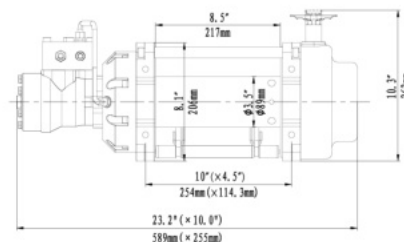

PERFORMANCE SPECS (first layer)

Line Pull Lbs.(kgs)	Pressure Mpa(Psi)	Flow G/min (L/min)	Line Speed Ft/min. (M/min.)
0	2.0(290.1)	1.3(5.0)	1.6(0.5)
5000(2268)	4.3(623.7)	2.6(10)	3.3(1.0)
10000(4536)	8.7(1261.8)	5.3(20.0)	6.6(2.0)
12000(5443)	10.0(1450.3)	7.9(30.0)	9.8(3.0)
15000(6804)	13.0(1885.4)	15.9(60.0)	19.7(6.0)



HWD 10000

SPECIFICATIONS

Rated line pull: 10000 lbs (4536 kgs)
Motor displacement: 50ml/r
Oil flow: 5~50L/min
Pressure: 9.5Mpa
Geartrain: 2-stage planetary alloy gear
Gear reduction ratio: High speed:13.6:1;Low speed:42.2:1
Cable(Dia×L): Ø3/8"×85'(Ø9.2mm×26m)
Drum size(Dia×L): Ø2.6"×8.54"(Ø66mm×217mm)
Mounting bolt pattern: 10"×4.5"(254mm×114.3mm)4-M12
Net weight: 99lbs/44.9kgs

DIMENSIONS

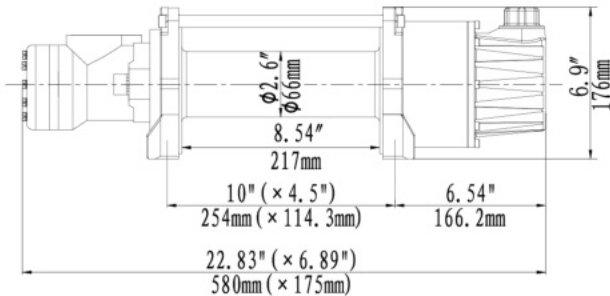

PERFORMANCE SPECS (first layer)

Line Pull	Pressure	Flow	Line Speed	Pull by layer:
Lbs.(kgs)	Mpa(Psi)	G/min. (L/min.)	Ft/min. (M/min.)	layer/Lbs.(kgs)
0	2.0(290.1)	1.3(5)	1.6(0.5)	1/10000(4536)
4000 (1814)	4.5(652.6)	2.6(10)	3.3(1.0)	2/7969(3615)
6000 (2722)	6.3(916.7)	5.2(20)	6.9(2.1)	3/6624(3005)
8000 (3629)	7.7(1120.4)	9.2(35)	12.1(3.7)	4/5667(2571)
10000 (4536)	9.5(1382.2)	13.2(50)	17.4(5.3)	

HWD 12000

SPECIFICATIONS

Rated line pull: 12000 lbs (5443 kgs)
Motor displacement: 50ml/r
Oil flow: 5~50L/min
Pressure: 11Mpa
Geartrain: 2-stage planetary alloy gear
Gear reduction ratio: High speed:13.6:1;Low speed:42.2:1
Cable(Dia×L): Ø13/32"×83.7'(Ø10.2mm×25.5m)
Drum size(Dia×L): Ø2.6"×8.54"(Ø66mm×217mm)
Mounting bolt pattern: 10"×4.5"(254mm×114.3mm)4-M12
Net weight: 102lbs/45.9kgs

DIMENSIONS

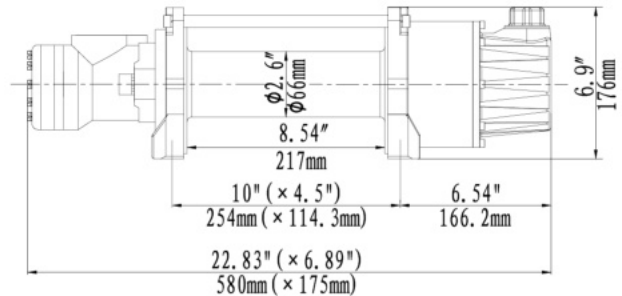

PERFORMANCE SPECS (first layer)

Line Pull	Pressure	Flow	Line Speed	Pull by layer:
Lbs.(kgs)	Mpa(Psi)	G/min. (L/min.)	Ft/min. (M/min.)	layer/Lbs.(kgs)
0	2.0(290.1)	1.3(5)	1.6(0.5)	1/12000(5443)
3000 (1814)	4.1(596.6)	2.6(10)	3.3(1.0)	2/9563(4338)
6000 (2722)	6.3(916.7)	5.2(20)	6.6(2.0)	3/7949(3606)
9000 (4082)	8.5(1236.8)	9.2(35)	12.5(3.8)	4/6801(3085)
12000 (5443)	11.0(1595.4)	13.2(50)	17.7(5.4)	



HWX 10000YD

SPECIFICATIONS

Rated line pull: 10000 lbs (4536 kgs)

Motor displacement: 50ml/r

Oil flow: 15~40L/min

Pressure: 12.5Mpa

Brake: Automatic screw cone

Geartrain: 2-stage planetary alloy gear

Gear reduction ratio: 28:1

Waterproof: IP54

Cable(Dia×L):

Ø3/8"×85'(Ø9.2mm×26m)

Drum size(Dia×L):

Ø2.6"×8.5"(Ø66mm×217mm)

Mounting bolt pattern:

19.7"×21.7"×5.0"

(500mm×550mm×126.3mm)8-M12

Net weight: 96.3lbs/43.7kgs

DIMENSIONS

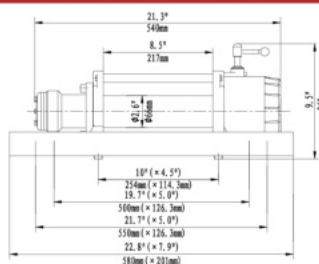

PERFORMANCE SPECS (first layer)

Line Pull	Pressure	Flow	Line Speed	Pull by layer:
Lbs.(kgs)	Mpa(Psi)	G/min. (L/min.)	Ft/min. (M/min.)	layer/Lbs.(kgs)
0	2.0(290.1)	4.0(15)	7.2(2.2)	1/10000 (4536)
4000 (1814)	3.9(565.6)	6.6(25)	12.5(3.8)	2/7969(3615)
6000 (2722)	7.5(1087.7)	9.2(35)	17.7(5.4)	3/6624(3005)
8000 (3629)	10.5(1522.8)	10.6(40)	20.0(6.1)	4/5667(2571)
10000 (4536)	12.5(1812.9)			



HWX 040H

SPECIFICATIONS

Rated line pull: 9000 lbs (4082 kgs)

Motor displacement: 80ml/r

Oil flow: 5~60L/min

Pressure: 11.5Mpa

Brake: Wet-type hydraulic brake

Geartrain: 2-stage planetary alloy gear

Gear reduction ratio: 23:1

Waterproof: IP54

Cable(Dia×L):

Ø13/32"×65.5'(Ø10.2mm×20m)

Drum size(Dia×L):

Ø3.5"×7.6"(Ø88mm×193mm)

Mounting bolt pattern:

11.8"×15.16"×11.0"

(300mm×385mm×280mm)8-M12

Net weight: 114.6lbs/52kgs

DIMENSIONS

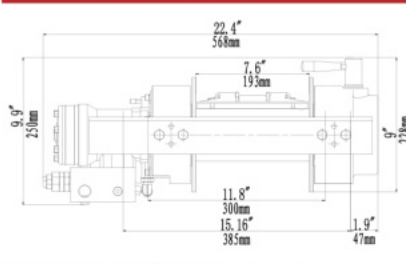

PERFORMANCE SPECS (first layer)

Line Pull	Pressure	Line Speed	Flow	Pull by layer:
Lbs.(kgs)	Mpa(Psi)	Ft/min. (M/min.)	G/min. (L/min.)	layer/Lbs.(kgs)
0	3.0(435.0)	3.6(1.1)	2.6(10)	1/9000 (4082)
4000 (1814)	6.5(942.5)	7.5(2.3)	5.3(20)	2/7452(3380)
6000 (2722)	8.5(1232.5)	15.7(4.8)	10.5(40)	3/6358(2884)
8000 (3629)	10.5(1522.5)	20.0(6.1)	13.2(50)	
9000 (4082)	11.5(1667.8)	24.2(7.4)	15.8(60)	



HWX 10000III

SPECIFICATIONS

Rated line pull: 10000 lbs (4536 kgs)

Motor displacement: 80ml/r

Oil flow: 15~60L/min

Pressure: 11.5Mpa

Brake: Automatic screw cone

Geartrain: 2-stage planetary alloy gear

Gear reduction ratio: 23:1

Waterproof: IP54

Cable(Dia×L):

Ø13/32"×65.5'(Ø10.2mm×20m)

Drum size(Dia×L):

Ø3.46"×7.6"(Ø88mm×193mm)

Mounting bolt pattern:

11.8"×15.2"×11.0"

(300mm×385mm×280mm)8-M12

Net weight: 105.8lbs/48kgs

DIMENSIONS

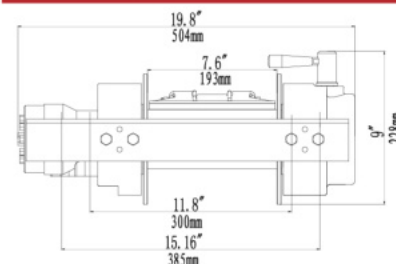

PERFORMANCE SPECS (first layer)

Line Pull	Pressure	Line Speed	Flow	Pull by layer:
Lbs.(kgs)	Mpa(Psi)	Ft/min. (M/min.)	G/min. (L/min.)	layer/Lbs.(kgs)
0	2.0(290.1)	3.6(1.1)	2.6(10)	1/10000 (4536)
4000 (1814)	4.7(681.6)	7.9(2.4)	5.2(20)	2/7969(3615)
6000 (2722)	6.9(1000.7)	15.7(4.8)	10.6(40)	3/6624(3005)
8000 (3629)	9.3(1348.8)	20.0(6.1)	13.2(50)	
10000 (4536)	11.5(1667.8)	24.3(7.4)	15.9(60)	

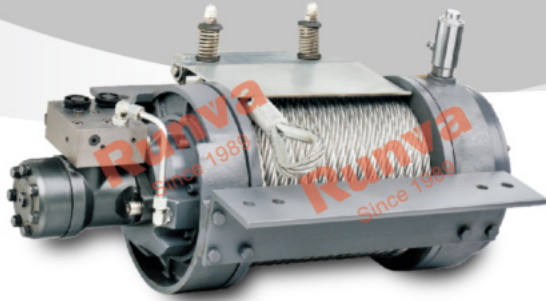

HWH 080

SPECIFICATIONS

Rated line pull: 17637 lbs (8000 kgs)
Motor displacement: 125ml/r
Oil flow: 15~50L/min
Pressure: 15Mpa
Brake: Wet-type hydraulic brake
Geartrain: 2-stage planetary alloy gear
Gear reduction ratio: 38:1
Waterproof: IP54
Cable(Dia×L): Ø9/16"×105'(Ø14mm×32m)
Drum size(Dia×L): Ø5.7"×10.8"(Ø144mm×275mm)
Mounting bolt pattern: 11.8"×15.0"×15.2"(300mm×380mm×386mm)8-M14
Net weight: 286.6lbs/130kgs

DIMENSIONS

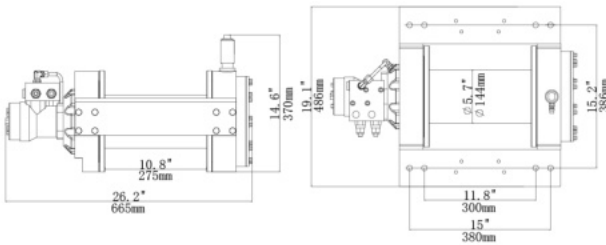

PERFORMANCE SPECS (first layer)

Line Pull Lbs.(kgs)	Pressure Mpa(Psi)	Flow G/min. (L/min.)	Line Speed Ft/min. (M/min.)	Pull by layer: layer/Lbs.(kgs)
0	2.0(290.1)	5.2(20)	5.9(1.8)	1/17637(8000)
4409 (2000)	4.2(609.2)	7.9(30)	8.2(2.5)	2/14980(6795)
8818 (4000)	7.8(1131.3)	10.6(40)	10.5(3.2)	3/13020(5906)
13228 (6000)	10.4(1508.4)	13.2(50)	13.1(4.0)	
17637 (8000)	13.8(2001.5)			



HWH 080I

SPECIFICATIONS

Rated line pull: 17637 lbs (8000 kgs)
Motor displacement: 125ml/r
Oil flow: 15~50L/min
Pressure: 15Mpa
Brake: Wet-type hydraulic brake
Geartrain: 2-stage planetary alloy gear
Gear reduction ratio: 38:1
Waterproof: IP54
Cable(Dia×L): Ø9/16"×105'(Ø14mm×32m)
Drum size(Dia×L): Ø5.7"×10.8"(Ø144mm×275mm)
Mounting bolt pattern: 15.7"×8.7"×4.7"(400mm×220mm×120mm)8-M14
Net weight: 304.2lbs/138kgs

DIMENSIONS

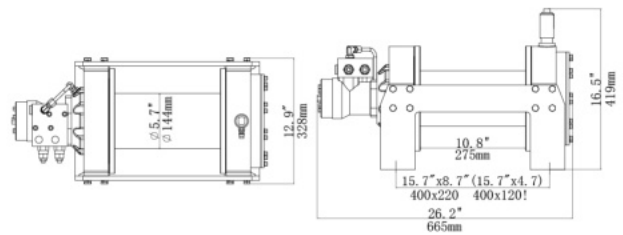

PERFORMANCE SPECS (first layer)

Line Pull Lbs.(kgs)	Pressure Mpa(Psi)	Flow G/min. (L/min.)	Line Speed Ft/min. (M/min.)	Pull by layer: layer/Lbs.(kgs)
0	2.0(290.1)	5.2(20)	5.9(1.8)	1/17637(8000)
4409 (2000)	4.2(609.2)	7.9(30)	8.2(2.5)	2/14980(6795)
8818 (4000)	7.8(1131.3)	10.6(40)	10.5(3.2)	3/13020(5906)
13228 (6000)	10.4(1508.4)	13.2(50)	13.1(4.0)	
17637 (8000)	13.8(2001.5)			



HWV 10000

SPECIFICATIONS

Rated line pull: 10000 lbs (4536 kgs)

Standard: European EN

Motor displacement: 100ml/r

Oil flow: 5~60L/min

Pressure: 15Mpa

Brake: Wet-type hydraulic brake

Geartrain: Planetary steel gear

Gear reduction ratio: 17.6:1

Clutch: Air, manual, air&manual optional

Waterproof: IP67

Cable(Dia×L): Ø13/32"×83.7'(Ø10.2mm×25.5m)

Drum size(Dia×L): Ø4.0"×10.0"(Ø102mm×253mm)

Mounting bolt pattern:

14.7"×4.5"(374.2mm×114.3mm)

11.5"×6.7"(291.6mm×171.2mm)8-M10

Net weight: 112.4lbs/51kgs



HWV 15000

SPECIFICATIONS

Rated line pull: 15000 lbs (6804 kgs)

Standard: European EN

Motor displacement: 160ml/r

Oil flow: 5~60L/min

Pressure: 17.5Mpa

Brake: Wet-type hydraulic brake

Geartrain: Planetary steel gear

Gear reduction ratio: 17.3:1

Clutch: Air, manual, air&manual optional

Waterproof: IP67

Cable(Dia×L): Ø15/32"×86.9'(Ø12mm×26.5m)

Drum size(Dia×L): Ø5.0"×10.5"(Ø127mm×266mm)

Mounting bolt pattern:

12.0"×4.5"(303.5mm×114.3mm)

14.5"×6.7"(368.5mm×171.2mm)8-M12

Net weight: 184.3lbs/83.6kgs

DIMENSIONS

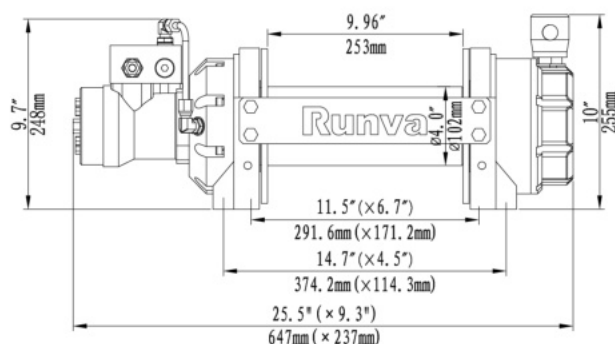

PERFORMANCE SPECS (first layer)

Line Pull	Pressure	Flow	Line speed	Pull by layer:
Lbs.(kgs)	Mpa(Psi)	G/min L/min	ft/min m/min	layer/Lbs.(kgs)
0	3.0(435.1)	1.3(5)	3.0(0.9)	1/10000(4536)
4000 (1814)	6.8(986.2)	2.6(10)	5.9(1.8)	2/7355(3336)
6000 (2722)	9.2(1334.3)	5.2(20)	11.8(3.6)	3/6780(3075)
8000 (3629)	12.0(1740.4)	10.4(40)	23.6(7.2)	4/5711(2591)
10000 (4536)	15.0(2175)	15.6(60)	36.1(11)	

DIMENSIONS

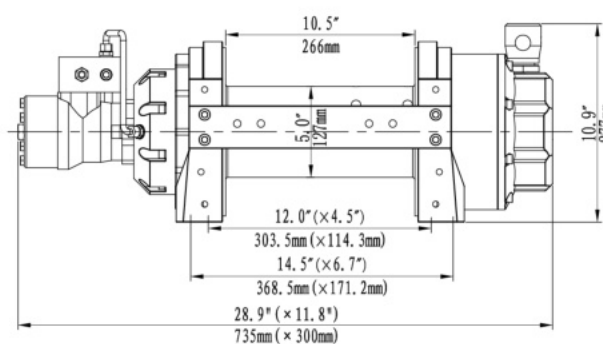

PERFORMANCE SPECS (first layer)

Line Pull	Pressure	Flow	Line speed	Pull by layer:
Lbs.(kgs)	Mpa(Psi)	G/min L/min	ft/min m/min	layer/Lbs.(kgs)
0	2.0(290)	2.6(10)	4.2(1.3)	1/15000(6804)
8000 (3629)	9.2(1337)	5.2(20)	8.5(2.6)	2/12791(5807)
10000 (4536)	11.5(1627)	7.9(30)	12.4(3.8)	3/11150(5062)
12000 (5448)	14.0(2030)	10.4(40)	16.7(5.1)	
15000 (6810)	17.5(2537)	15.6(60)	23(7.0)	

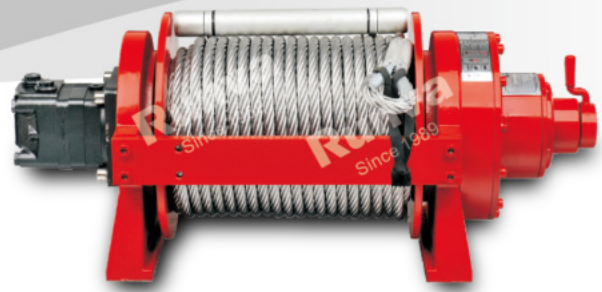
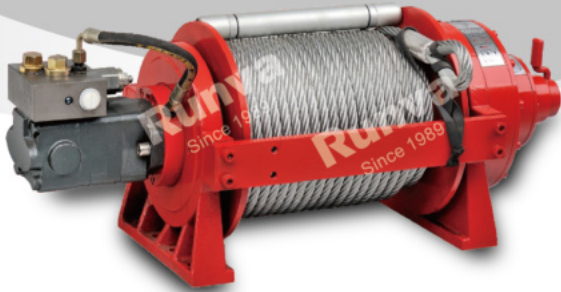

HWP 2000YP

SPECIFICATIONS

Rated line pull: 20000 lbs (9072 kgs)
Motor displacement: 100ml/r
Oil flow: 15~75L/min
Pressure: 17.5Mpa
Brake: Hydraulic multi-disc
Geartrain: 2-stage planetary steel gear
Gear reduction ratio: High speed:6:1;Low speed:39:1
Clutch: Air,manual,air&manual optional
Cable(Dia×L): Ø9/16"×157'(Ø14mm×48m)
Drum size(Dia×L): Ø5.4"×12.4"(Ø138mm×316mm)
Mounting bolt pattern: 17.0"×2.5"×7.6"(431mm×64mm×192mm)8-M14
Net weight: 360lbs/163kgs

DIMENSIONS

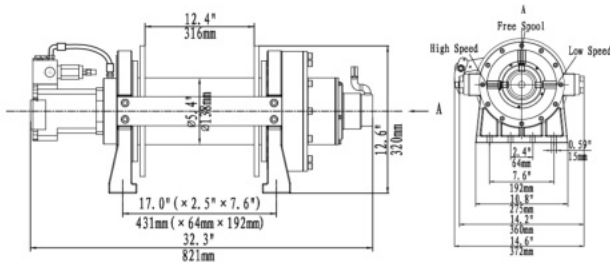

PERFORMANCE SPECS (first layer)

Line Pull	Pressure	Flow	Line Speed	Pull by layer:
Lbs.(kgs)	Mpa(Psi)	G/min L/min	Ft/min. (M/min.)	layer/Lbs.(kgs)
0	2.5(362.6)	4.0(15)	5.9(1.8)	1/20000 (9072)
4000 (1814)	4.2(609.2)	7.9(30)	11.8(3.6)	2/16889(7661)
8000 (3629)	8.5(1232.8)	13.2(50)	19.7(6.0)	3/14615(6630)
15000 (6804)	14.0(2030.5)	15.9(60)	23.6(7.2)	4/12881(5843)
20000 (9072)	17.5(2538.1)	19.9(75)	29.5(9.0)	

HWP 2000YD

SPECIFICATIONS

Rated line pull: 20000 lbs (9072 kgs)
Motor displacement: 100ml/r
Oil flow: 15~75L/min
Pressure: 17.5Mpa
Brake: screw multi-disc
Geartrain: 2-stage planetary steel gear
Gear reduction ratio: High speed:6:1;Low speed:39:1
Clutch: Air,manual,air&manual optional
Cable(Dia×L): Ø9/16"×157'(Ø14mm×48m)
Drum size(Dia×L): Ø5.4"×12.4"(Ø138mm×316mm)
Mounting bolt pattern: 17.0"×2.5"×7.6"(431mm×64mm×192mm)8-M14
Net weight: 360lbs/163kgs

DIMENSIONS

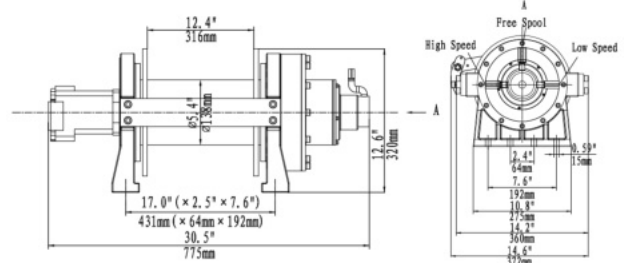

PERFORMANCE SPECS (first layer)

Line Pull	Pressure	Flow	Line Speed	Pull by layer:
Lbs.(kgs)	Mpa(Psi)	G/min L/min	Ft/min. (M/min.)	layer/Lbs.(kgs)
0	2.5(362.6)	4.0(15)	5.9(1.8)	1/20000 (9072)
4000 (1814)	4.2(609.2)	7.9(30)	11.8(3.6)	2/16889(7661)
8000 (3629)	8.5(1232.8)	13.2(50)	19.7(6.0)	3/14615(6630)
15000 (6804)	14.0(2030.5)	15.9(60)	23.6(7.2)	4/12881(5843)
20000 (9072)	17.5(2538.1)	19.9(75)	29.5(9.0)	

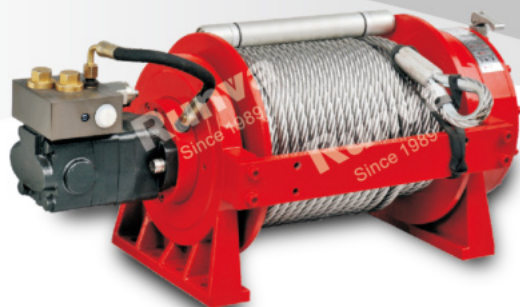

HWX 20000YP

SPECIFICATIONS

Rated line pull: 20000 lbs (9072 kgs)
Motor displacement: 100ml/r
Oil flow: 15~75L/min
Pressure: 17.5Mpa
Brake: Hydraulic multi-disc
Geartrain: 2-stage planetary steel gear
Gear reduction ratio: 39:1
Cable(Dia×L): Ø9/16"×157'(Ø14mm×48m)
Drum size(Dia×L): Ø5.4"×12.4"(Ø138mm×316mm)
Mounting bolt pattern: 17.0"×2.5"×7.6"(431mm×64mm×192mm)8-M14
Net weight: 238lbs/108kgs

DIMENSIONS

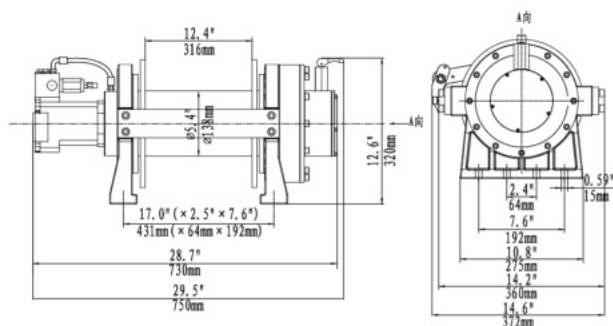

PERFORMANCE SPECS (first layer)

Line Pull	Pressure	Flow	Line speed	Pull by layer:
Lbs.(kgs)	Mpa(Psi)	G/min L/min	ft/min m/min	layer/Lbs.(kgs)
0	2.5(362.6)	4.0(15)	5.9(1.8)	1/20000 (9072)
4000 (1814)	4.2(609.1)	7.9(30)	11.8(3.6)	2/16889(7661)
8000 (3629)	8.5(1232.8)	13.2(50)	19.7(6.0)	3/14615(6629)
15000 (6804)	14.0(2030.5)	15.9(60)	23.6(7.2)	4/12881(5843)
20000 (9072)	17.5(2538.1)	19.9(75)	29.5(9.0)	



HWX 20000YD

SPECIFICATIONS

Rated line pull: 20000 lbs (9072 kgs)
Motor displacement: 100ml/r
Oil flow: 15~75L/min
Pressure: 17.5Mpa
Brake: screw multi-disc
Geartrain: 2-stage planetary steel gear
Gear reduction ratio: 39:1
Drum size(Dia×L): Ø5.4"×10.2"(Ø138mm×260mm)
Mounting bolt pattern: 14.8"×2.5"×7.6"(375mm×64mm×192mm)8-M14
Net weight: 238lbs/108kgs

DIMENSIONS

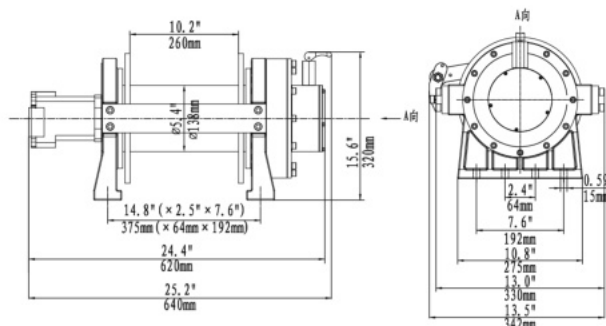

PERFORMANCE SPECS (first layer)

Line Pull	Pressure	Flow	Line speed
Lbs.(kgs)	Mpa(Psi)	G/min L/min	ft/min m/min
0	2.5(362.6)	4.0(15)	5.9(1.8)
4000 (1814)	4.2(609.1)	7.9(30)	11.8(3.6)
8000 (3629)	8.5(1232.8)	13.2(50)	19.7(6.0)
15000 (6804)	14.0(2030.5)	15.9(60)	23.6(7.2)
20000 (9072)	17.5(2538.1)	19.9(75)	29.5(9.0)

Runva

Since 1989



HWE SERIES

Designed with EN standard, the HWE Series provide reliable, powerful performance. Wet-type hydraulic brake delivers heavy braking torque, long life and stable transmission. Capacities up to 30 tons make this line for wide application in engineering vehicle, wrecker and recovery.

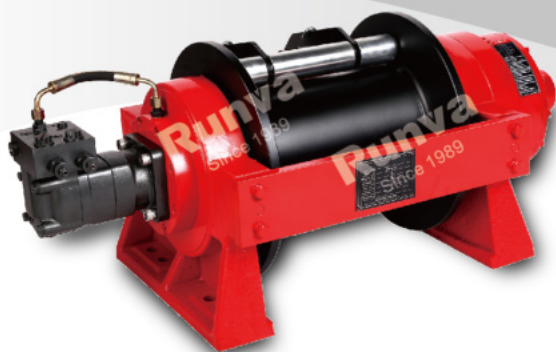

HWE 100

SPECIFICATIONS

Rated line pull: 22000 lbs (10000 kgs)
Motor displacement: 200ml/r
Oil flow: 15~75L/min
Pressure: 16Mpa
Brake: Wet-type hydraulic brake
Geartrain: 2-stage planetary alloy gear
Gear reduction ratio: 37.8:1
Waterproof: IP67
Cable(Dia×L): Ø5/7"×131'(Ø18mm×40m)
Drum size(Dia×L): Ø7.46"×13.39"(Ø189.5mm×340mm)
Mounting bolt pattern: 20.55"×7.09"×11.02"(522mm×180mm×280mm)8-M20
Net weight: 260kg

DIMENSIONS

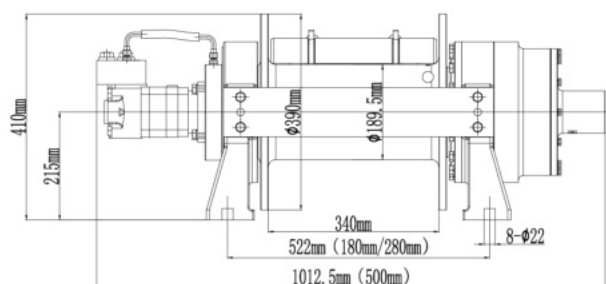

PERFORMANCE SPECS (first layer)

Line Pull Lbs.(kgs)	Pressure Mpa(Psi)	Flow G/min L/min	Line speed ft/min m/min	Pull by layer: layer/Lbs.(kgs)
0	3.5(507.5)	4.0(15)	4.3(1.3)	1/22000 (10000)
14500 (6577)	7(1015)	10.6(40)	10.8(3.3)	2/18700 (8482)
16300 (7394)	10.5(1522.5)	13.2(50)	13.5(4.1)	3/16300 (7394)
18700 (8482)	14(2030)	15.9(60)	15.8(4.8)	4/14500 (6577)
22000 (10000)	16(2320)	19.8(75)	20.0(6.1)	

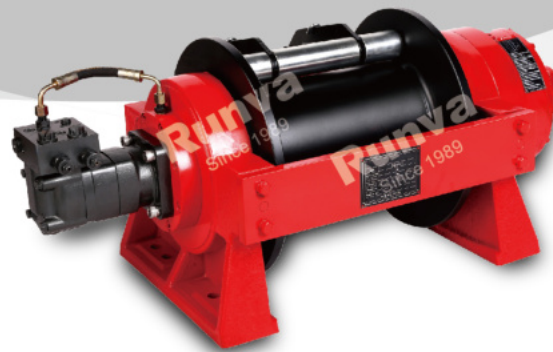

HWE 150

SPECIFICATIONS

Rated line pull: 33000 lbs (15000 kgs)
Motor displacement: 250ml/r
Oil flow: 10~120L/min
Pressure: 20Mpa
Brake: Wet-type hydraulic brake
Geartrain: 2-stage planetary alloy gear
Gear reduction ratio: 40.6:1
Waterproof: IP67
Cable(Dia×L): Ø7/8"×131'(Ø22mm×40m)
Drum size(Dia×L): Ø8.27"×13.39"(Ø210mm×340mm)
Mounting bolt pattern: 20.55"×7.09"×11.02"(522mm×180mm×280mm)8-M20
Net weight: 300kg

DIMENSIONS

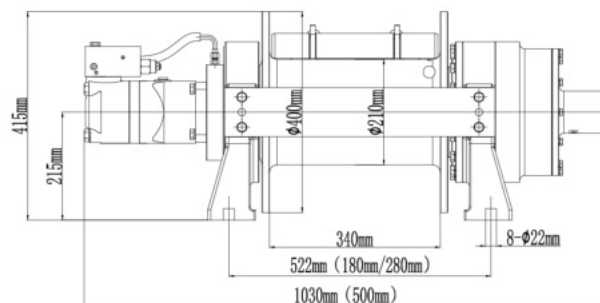

PERFORMANCE SPECS (first layer)

Line Pull Lbs.(kgs)	Pressure Mpa(Psi)	Flow G/min L/min	Line speed ft/min m/min	Pull by layer: layer/Lbs.(kgs)
0	4(580.2)	5.3(20)	4.3(1.3)	1/33000 (15000)
21000 (9526)	10(1450.4)	15.9(60)	13.8(4.2)	2/27700 (12565)
23900 (10841)	12(1740.5)	21.1(80)	18(5.5)	3/23900 (10841)
27700 (12565)	15(2175.6)	26.4(100)	22.6(6.9)	4/21000 (9526)
33000 (15000)	18(2610.7)	33(125)	27.9(8.5)	



HWE 200

SPECIFICATIONS

Rated line pull: 44000 lbs (20000 kgs)

Motor displacement: 315ml/r

Oil flow: 10~120L/min

Pressure: 20Mpa

Brake: Wet-type hydraulic brake

Geartrain: 2-stage planetary alloy gear

Gear reduction ratio: 36:1

Waterproof: IP67

Cable(Dia×L): Ø1.02"×131'(Ø26mm×40m)

Drum size(Dia×L): Ø8.27"×13.39"(Ø210mm×340mm)

Mounting bolt pattern:

20.94"×6.3"×11.02"(532mm×160mm×280mm)8-M24

Net weight: 380kg

HWE 300

SPECIFICATIONS

Rated line pull: 66000 lbs (30000 kgs)

Motor displacement: 500ml/r

Oil flow: 10~120L/min

Pressure: 16Mpa

Brake: Wet-type hydraulic brake

Geartrain: 2-stage planetary alloy gear

Gear reduction ratio: 53:1

Waterproof: IP67

Cable(Dia×L): Ø1.26"×131'(Ø32mm×40m)

Drum size(Dia×L): Ø10.63"×14.2"(Ø270mm×360mm)

Mounting bolt pattern:

24"×6.7"×11.2"(610mm×170mm×310mm)8-M27

Net weight: 700kg

DIMENSIONS

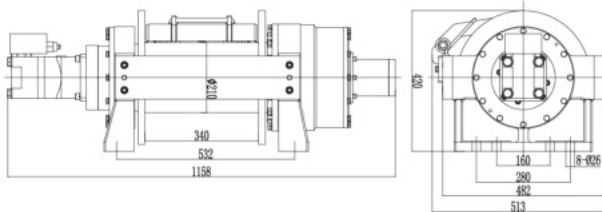

PERFORMANCE SPECS (first layer)

Line Pull	Pressure	Flow	Line speed	Pull by layer:
Lbs.(kgs)	Mpa(Psi)	G/min L/min	ft/min m/min	layer/Lbs.(kgs)
0	7.5(1087.8)	5.3(20)	3.3(1.0)	1/44000(20000)
22000(10000)	10(1450.4)	13.2(50)	8.9(2.7)	2/36128(16388)
33000(15000)	15(2175.6)	22.5(85)	15.4(4.7)	3/30600(13882)
44000(20000)	20(2900.8)	31.7(120)	23.0(7.0)	4/26543(12040)

DIMENSIONS

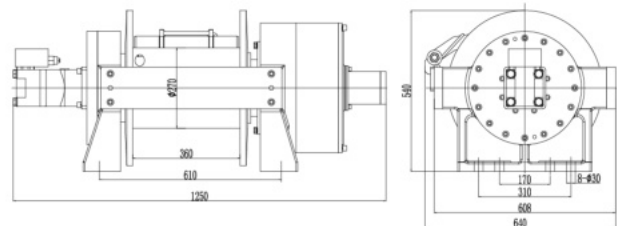

PERFORMANCE SPECS (first layer)

Line Pull	Pressure	Flow	Line speed	Pull by layer:
Lbs.(kgs)	Mpa(Psi)	G/min L/min	ft/min m/min	layer/Lbs.(kgs)
0	7(1015.3)	5.3(20)	2.0(0.6)	1/66000(30000)
44000(20000)	11(1595.4)	13.2(50)	5.2(1.6)	2/54572(24754)
55000(25000)	14(2030.5)	22.5(85)	9.8(3.0)	3/46450(21070)
66000(30000)	16(2320.6)	31.7(120)	13.5(4.1)	4/40432(18340)



HWT SERIES

Designed with EN standard the HWT Series provide reliable, powerful performance. 2-Stage planetary gear reducer delivers stable transmission under heavy duty. Long-time work makes wide application in engineering vehicle wrecker and recovery.

HWT015

SPECIFICATIONS

Rated line pull: 3300 lbs(1500Kg)

Motor displacement: 160ml/r

Oil flow: 5-60L/min

Pressure: 14Mpa

Gear reduction ratio: 5.7 : 1

Cable(Dia×L): Ø25/64"×123' (Ø10mm×37.5m)

Drum size(Dia×L): Ø6.3"×6.5"(Ø160mm×165mm)

Mounting bolt pattern:

6.1"×9.05"(155mm×230mm) 4-M16

Overall dimensions 13"×11.8"×11.7"

(L×W×H) 330mm×300mm×296.5mm

Net weight: 155.6lbs/70.6kg



DIMENSIONS

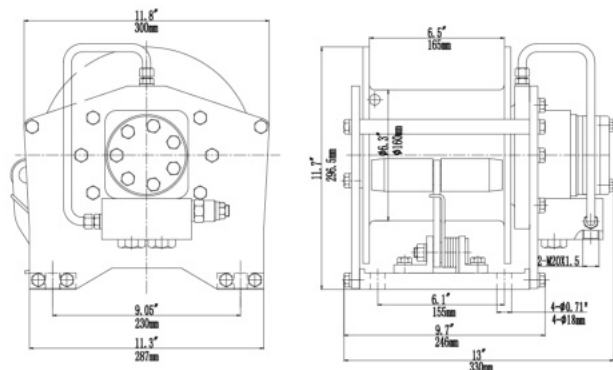

PERFORMANCE SPECS

Pressure	14Mpa			
Oil flow	50L/min			
Layer of wire rope	1	2	3	4
Rated line pull lbs(kg)	3300(1500)	3000(1360)	2720(1234)	2475(1123)
Line speed ft/min(m/min)	98.4(30)	110(33.5)	121.4(37)	133.2(40.6)
Total rope on drum ft (m)	26.2(8)	55.8(17)	88.6(27)	123(37.5)



ACCESSORIES **AND OTHER PRODUCT**

ACCESSORIES

WSR:Wireless Switch Receiver



WSR3 (US Standard)
WSR4 (Euro Standard)



WSR5(US Standard)
WSR6(Euro Standard)



WSE2



WSE3



WSE4



WSE7

RC:Vary Kinds of Switch



RC1



RC3



RC4



RC6



RC7



RC8



RCH



RCD2000-3000

Core of Controls



SN200



SN250



SN300



SN400



SN600

QC : Quick Connector for Electric Wire



QC20
(MAX.200A)

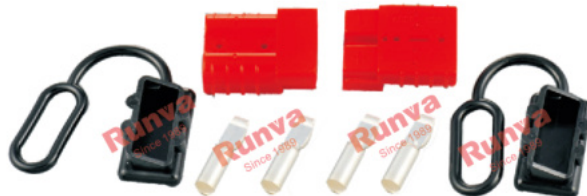

QC50
(MAX.500A)

ACCESSORIES

RF is Default SRF:Stainless Roller Fairlead



Aluminium Fairlead-For Synthetic Rope



SNB:Need to Supply Snatch Block



QM:QUICK Mouting Plate



ACCESSORIES

IST:Winch Installation Plate



IST3000



IST3500



IST4500T



IST4500X



IST8000A



IST9500SG2



IST15000N



IST17500

TS:Tow Strap & Tree Trunk Saves



TS3-2
(25mmX2000mm)
(2.5T)



TS15-2
(75mmX2000mm)
(8T)



TS15-2.5



TS15-3

Rope



Steel Rope



SYNTHETIC ROPE

Accessory Kits



ACCESSORIES

Hook



DSK:D Type Shackle



BSK:Bow Type Shackle



Other Accessory



Runva

Since 1989

ZHEJIANG RUNVA MECHANICAL& ELECTRICAL CO.,LTD



Factory Add1: No.100 Wancang Road,Jinpan Development Zone,Jinhua,Zhejiang,China



Factory Add2: No.1 Jinlong Road,Wucheng District,Jinhua,Zhejiang,China.



Tel: +86-(0)579-83930166



E-mail: sales@runva.com



Fax: +86-(0)579-83930890



Website: www.runva.com www.chinawinch.com



www.runva.com

